

AMGO  [®] **Hydraulics**

Original

Installation And Service Manual

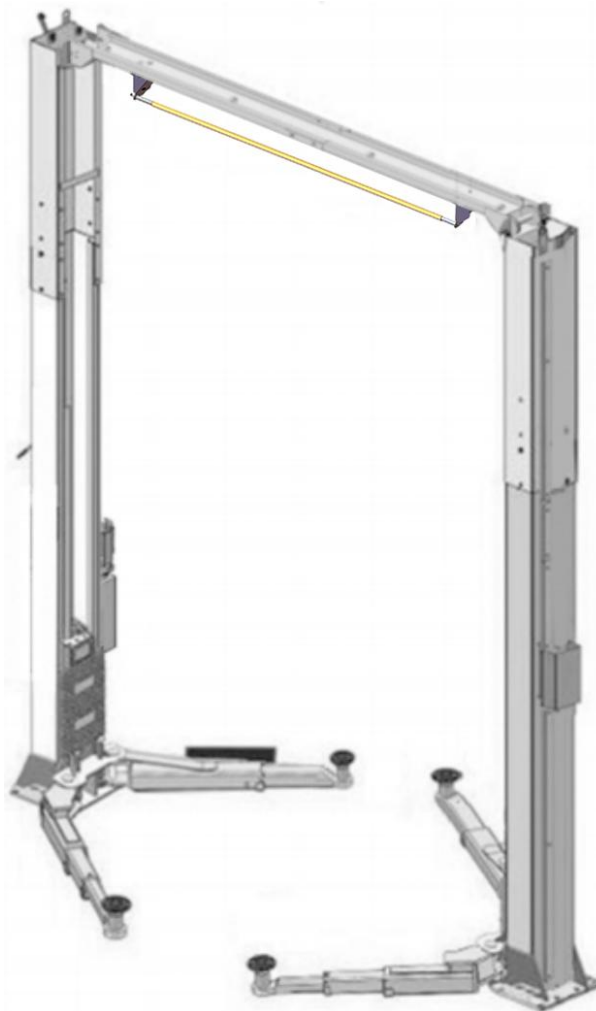

TWO POST LIFT
Model: OH-10

CONTENTS

Product Features and Specifications	1
Installation Requirement	4
Steps of Installation	6
Exploded View	25
Test Run	33
Operation Instruction	35
Maintenance	35
Trouble Shooting	37
Lift Disposal	37

I. PRODUCT FEATURES AND SPECIFICATIONS

CLEAR-FLOOR DIRECT-DRIVED MODEL FEATURES

Model OH-10 (See Fig. 1)

- Direct-driven design, minimize the lift spare parts breakdown ratio
- Dual hydraulic cylinders, each cylinder has been through high pressure holding test, adopts imported oil ring for cylinder sealing
- Self-lubricating UHMW Polyethylene sliders and bronze bush
- Single-point safety release device
- Super-asymmetric arms design, convenient to open car doors
- Clear-floor design, provide unobstructed floor use
- Overhead safety stop device prevents vehicle damage
- Stackable rubber pads
- Standard adjustable heights accommodate varying ceiling heights



Fig. 1

OH-10 SPECIFICATIONS

Model	Lifting Capacity	Lifting Height	Lifting Time	Overall Height	Overall Width	Width Between Columns	Minimum Pad Height	Motor
OH-10	10,000lbs	71-1/2"~84-1/2"	56S	142-1/2"/150-1/2"	135"	112-1/4"	3-1/2"~12-1/2"	2.0HP

Arm Swings View

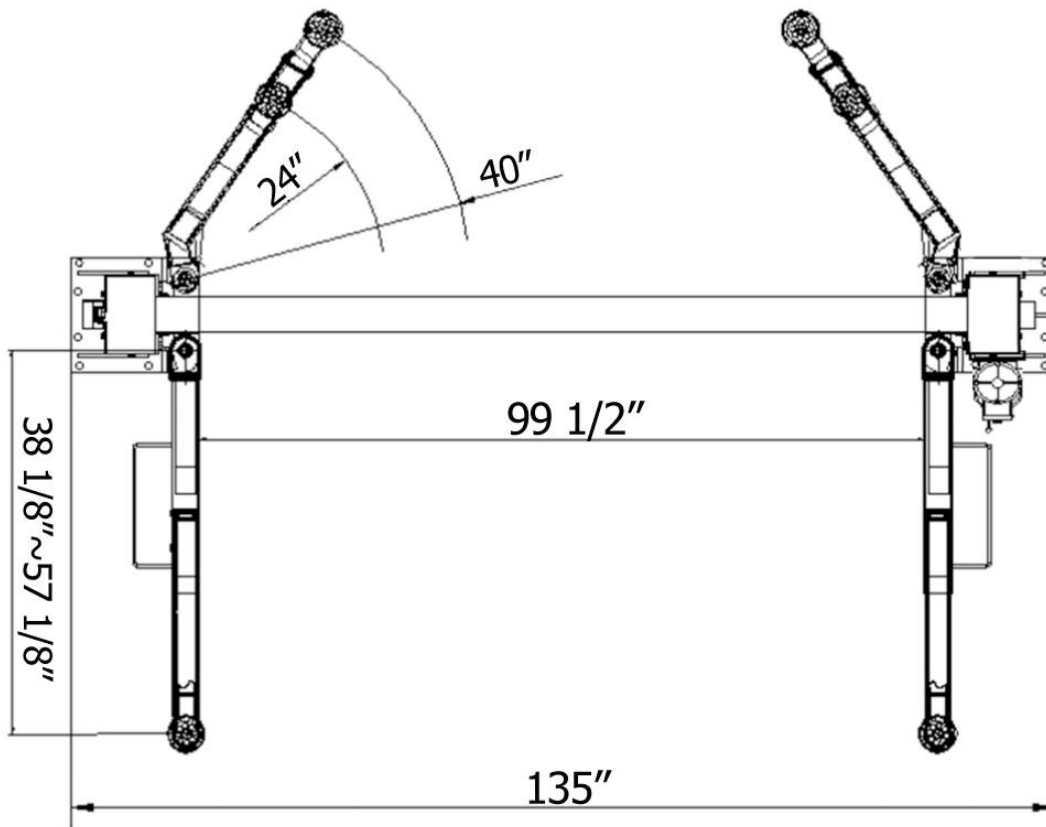

Fig.2

Attention! Please make sure to place the arms in correct position before car drive in!

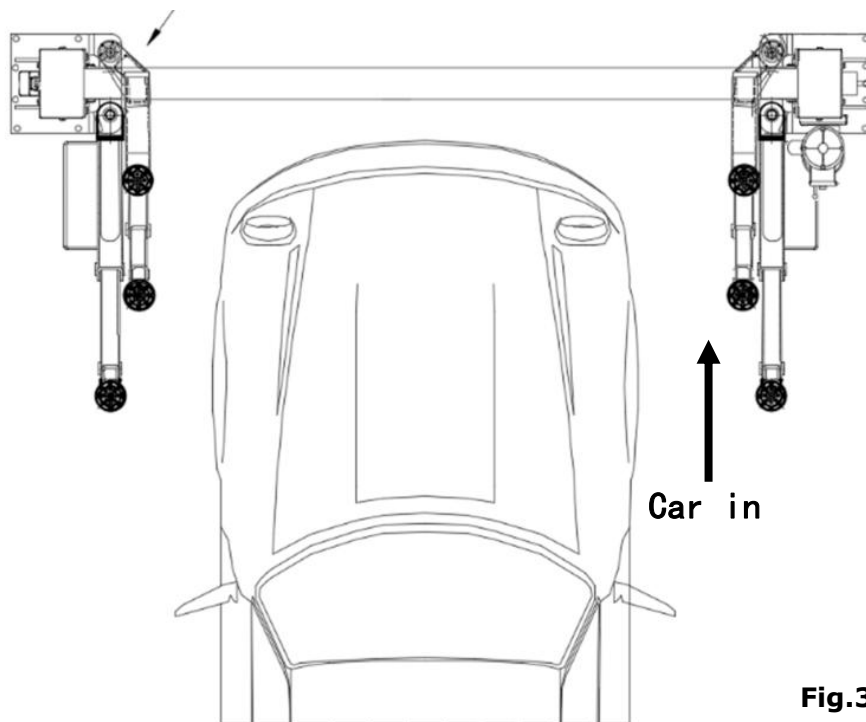

Fig.3

Swing and extending the arms to the lifting point of vehicle

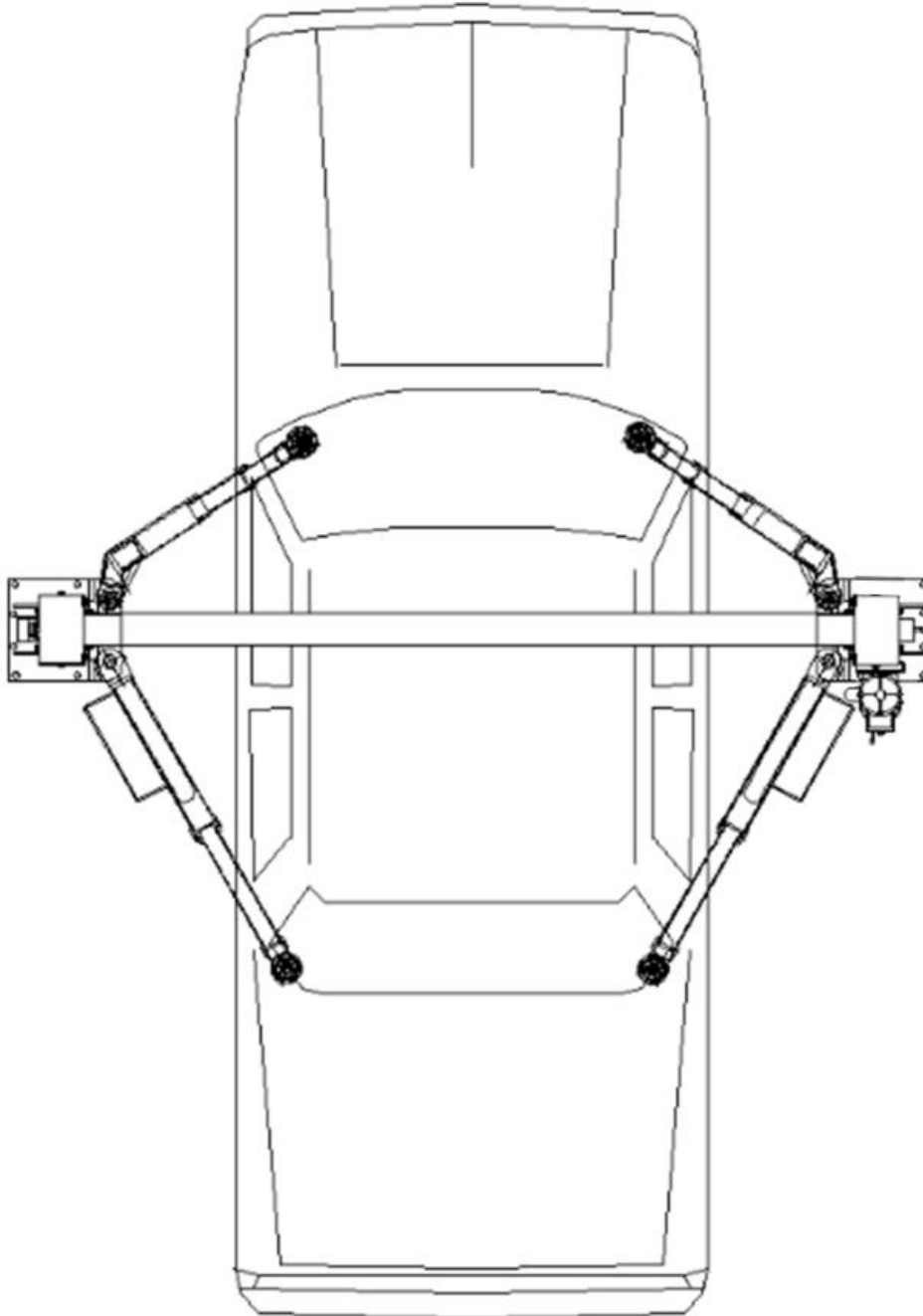

Fig.4

II. INSTALLATION REQUIREMENT

A. TOOLS REQUIRED

- ✓ Rotary Hammer Drill ($\Phi 19$)



- ✓ Hammer



- ✓ Level Bar



- ✓ English Spanner (12")



- ✓ Ratchet Spanner with Socket (28#)



↳

Wrench set

(8#, 10#, 13#, 14#, 17#, 19#, 24#)



- ✓ Carpenter's ink marker



- ✓ Screw Sets



- ✓ Tape Measure (7.5m)



- ✓ Pliers



- ✓ Socket Head Wrench (3#, 5#, 8#)



↳

Lock Wrench



Fig.5

B. Equipment storage and installation requirements.

The equipment should be stored or installed in a shady, normal temperature, ventilated and dry place.

C. The equipment should be unloaded and transferred by forklift.



Fig.6

D. SPECIFICATIONS OF CONCRETE (See Fig. 7)

Specifications of concrete must be adhered to the specification as following.

Failure to do so may result in lift and/or vehicle falling.

1. Concrete must be thickness 4" minimum and without reinforcing steel bars, and must be dried completely before the installation.
2. Concrete must be in good condition and must be of test strength 3,000psi minimum.
3. Floors must be level and no cracks.

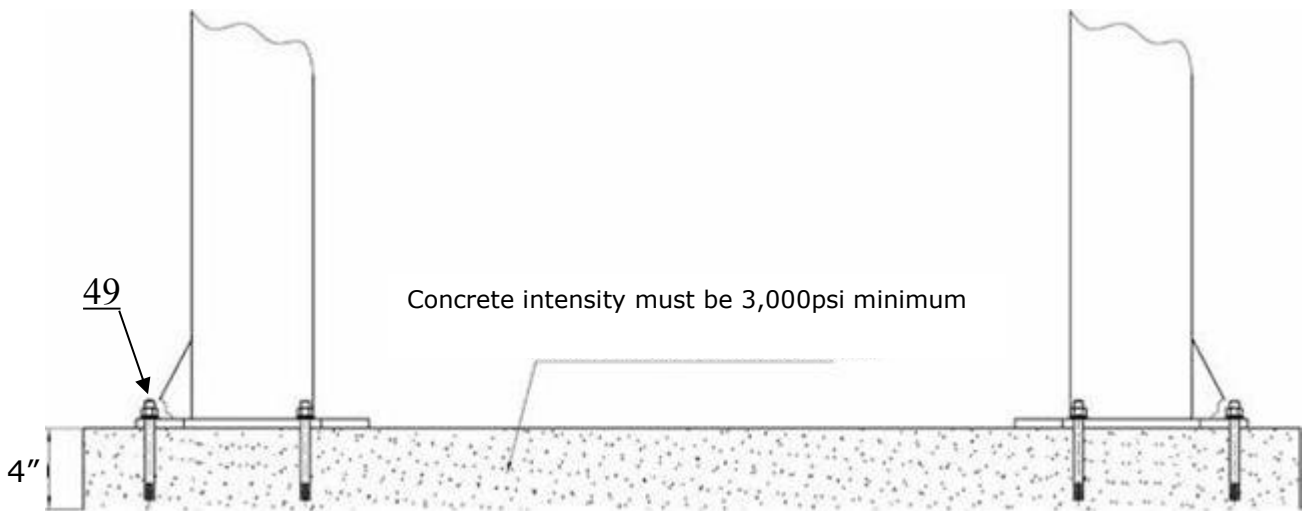

Fig. 7

E. POWER SUPPLY

The electrical source must be 3.0HP minimum. The source cable size must be 2.5mm² and in good condition of contacting with floor.

III. STEPS OF INSTALLATION

A. Location of Installation

Check and insure the installation location (concrete, layout, space size etc.) is suitable for lift installation.

B. Use a carpenter's ink marker line to establish installation layout of base-plate (See Fig.8).

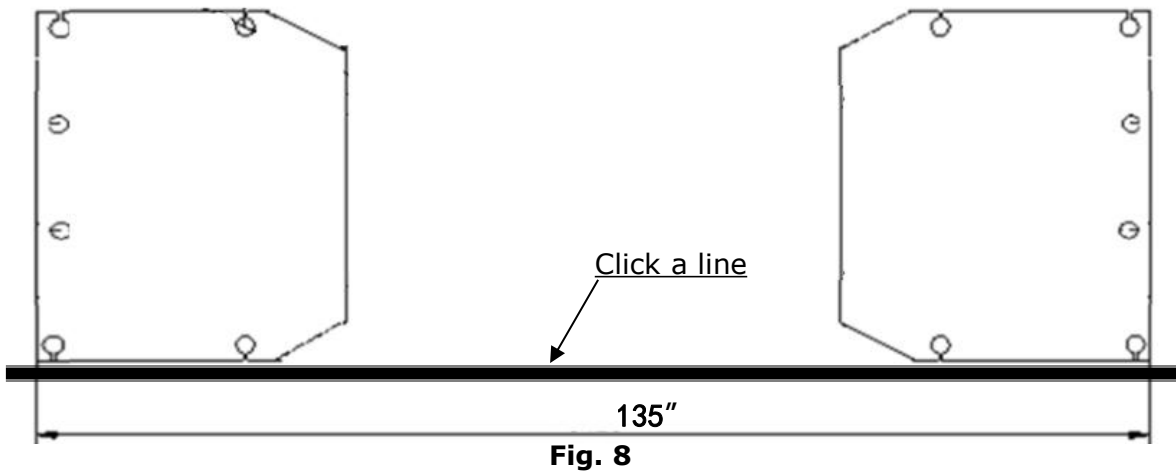

C. Check the parts before assembly.

1. Packaged lift and power unit (See Fig. 9).



2. Move aside the lift with fork lift or hoist, and open the extension packing carefully, take off the lifting arms and parts box from upper and inside the column, then move them to location nearby installation site, check the parts according to the shipment parts list (See Fig.10).

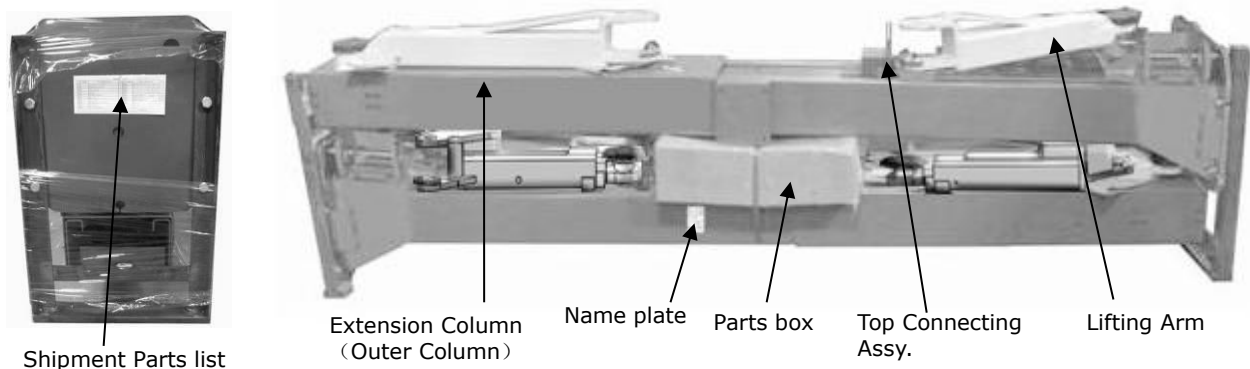

- Loose the screws of the upper package stand, take off the upper extension columns, take out the parts in the inner column and remove the package stand.
- Move aside the parts and check the parts according to the shipment parts list.

(See Fig.11, 12).

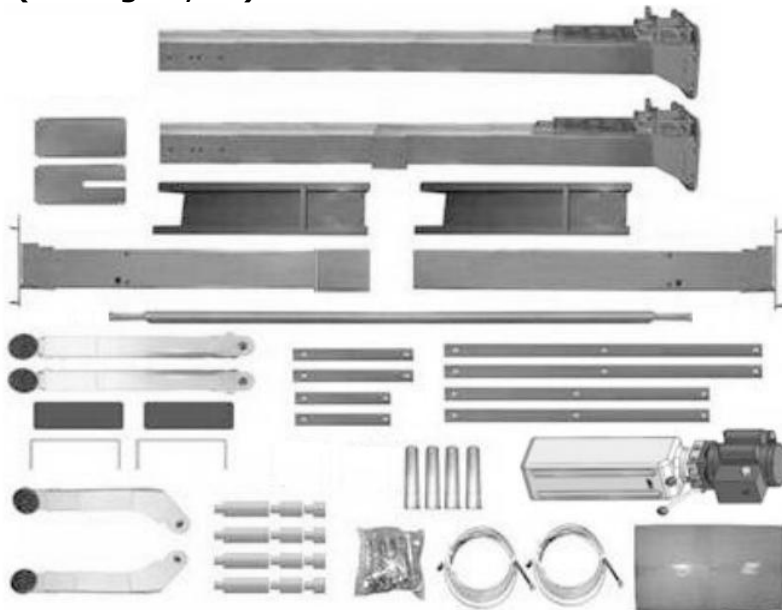

Fig. 11
Parts in the shipment parts list



Fig. 12
Parts in the parts box (50)

50

- Open the bag 1 and the bag 2 of parts; check the parts according to parts box list (See Fig. 13).



Parts bag (1)



Part bag (2)



Fig. 13

- Open the bag 3 of parts and check the parts according to parts bag list (See Fig. 14).

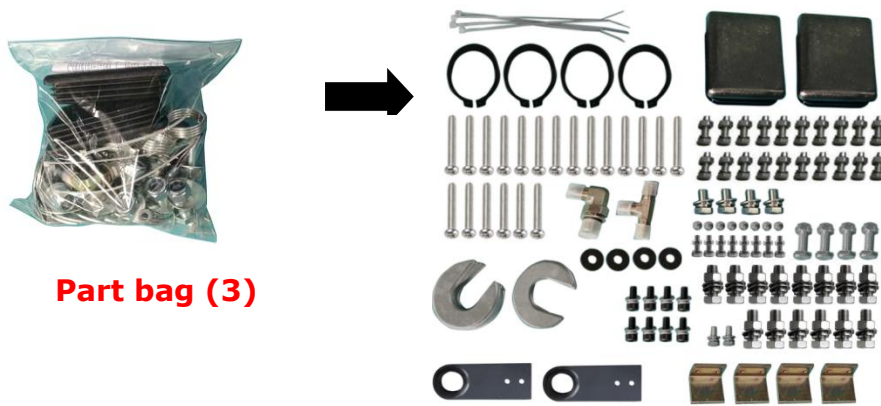

Part bag (3)

Fig. 14

D. Install parts of extension columns (See Fig. 15).

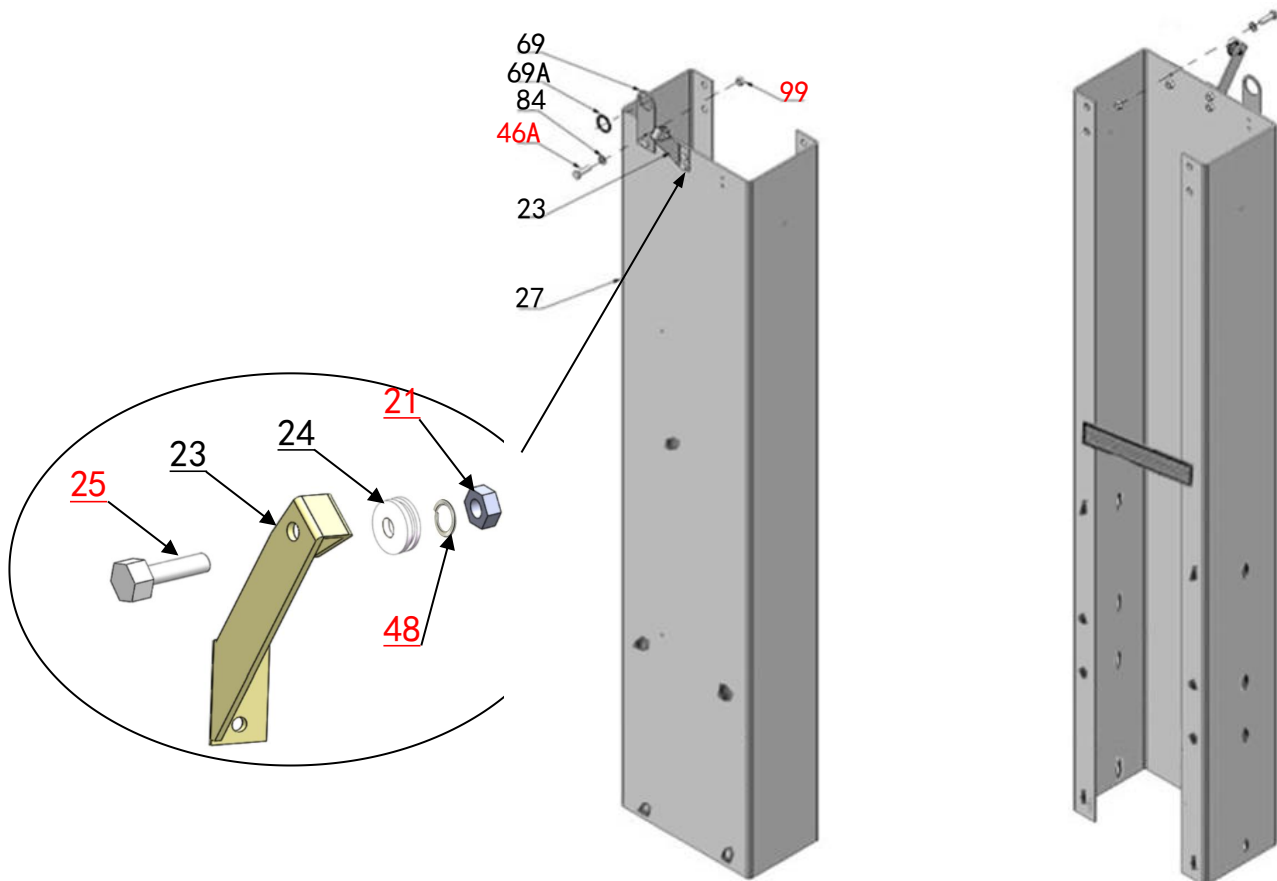

E. Position power-side column

Put down two columns on the installation site parallelly. Position the power-side column according to the actual installation site. Usually, it is suggested to install power-side column on the front-right side of the direction which vehicles are driven to the lift. This lift is designed with 2-Section columns. Adjust the height according to the ceiling height and connect the inner and extension columns.

Not suitable for installation when the height of the workshop is less than 143-3/4"; only low setting installation for ceiling height between 143-3/4" ~ 151-1/2 "; the height of the workshop is greater than 151-1/2", installation can be in both high and low setting;

1. High setting installation, choose the low holes of the outer column and install with the inner column.

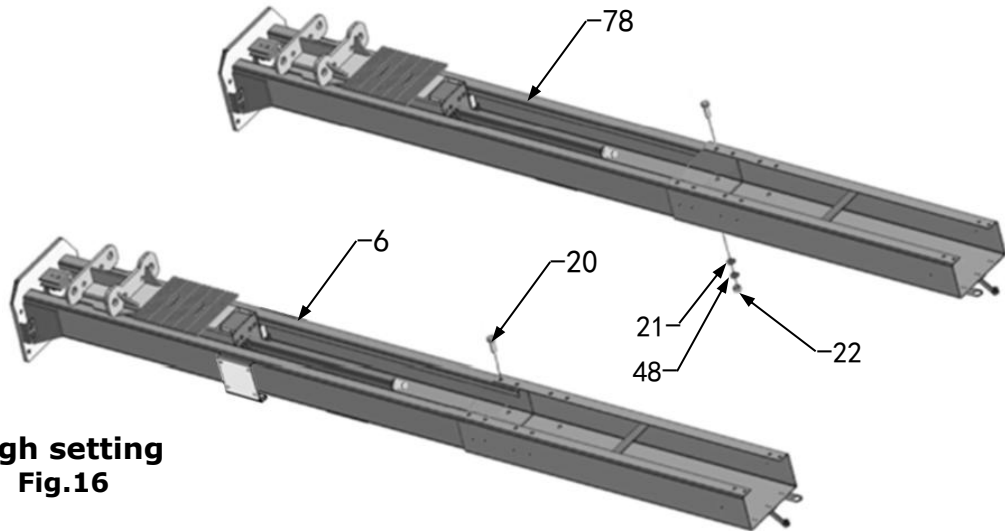

High setting
Fig.16

2. Low setting installation, choose the high position holes of the outer column and install with the inner column. (See Fig.17).

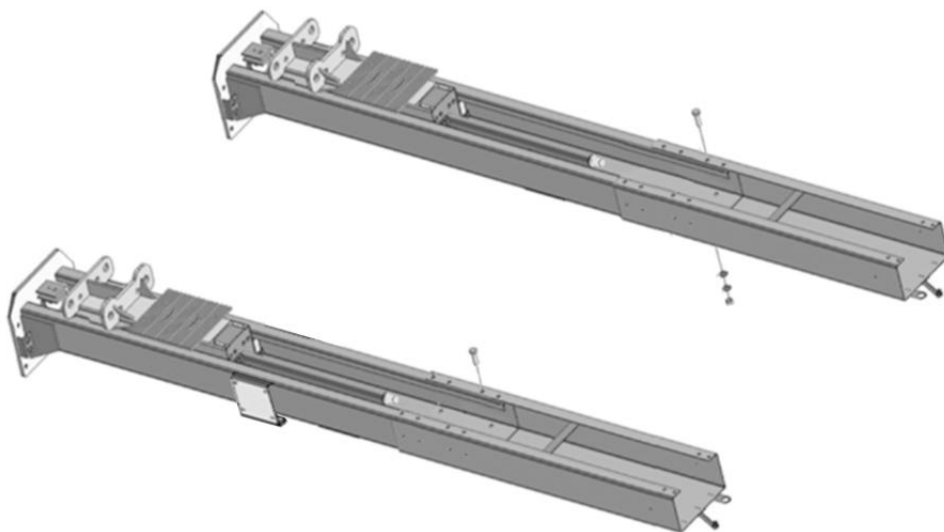

Low setting
Fig.17

F. Position columns (See Fig. 18)

Position the columns on the installation layout of base-plate, Install the anchor bolts. Check the Columns plumpness with level bar, and adjusting with the shims if the columns are not vertical. Do not tighten the Anchor Bolts.

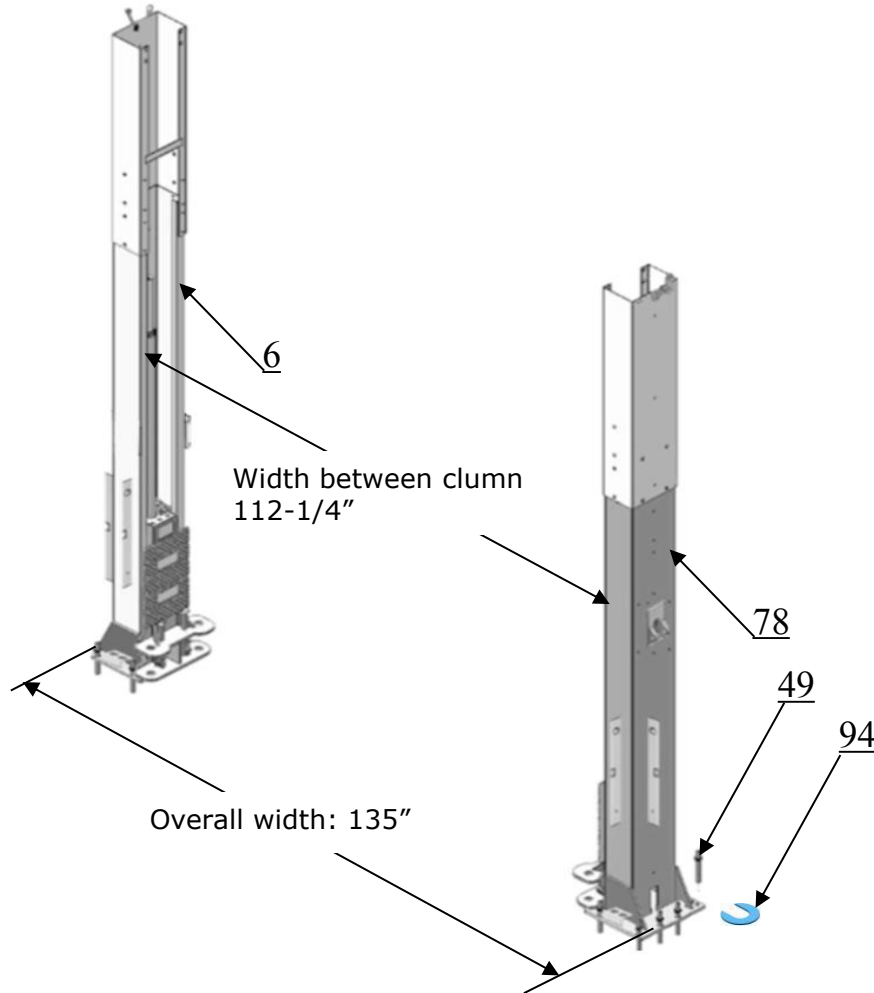

Note: Minimum embedment depth of anchors is 3-1/2".



Fig. 18

G. Install overhead top beam

1. The hook on the top coupling assembly is hung on the outer column to lock the screws, and then the top beam is installed (**See Fig. 19**).



Fig. 19

2. Install the top beam, fix the anchor bolts.

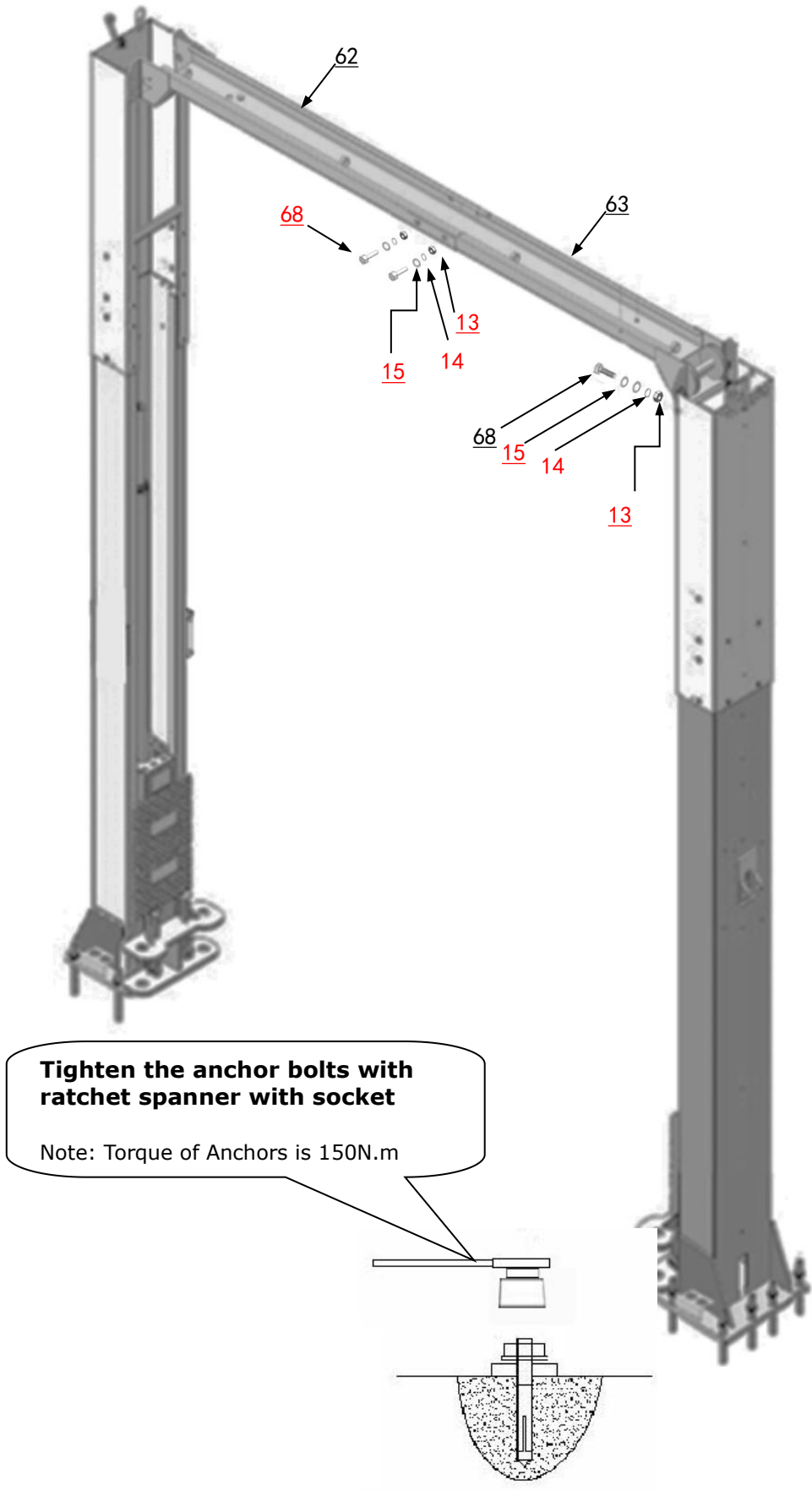

Fig.20

H. Install the limit switch control bar and limit switch (See Fig. 21).

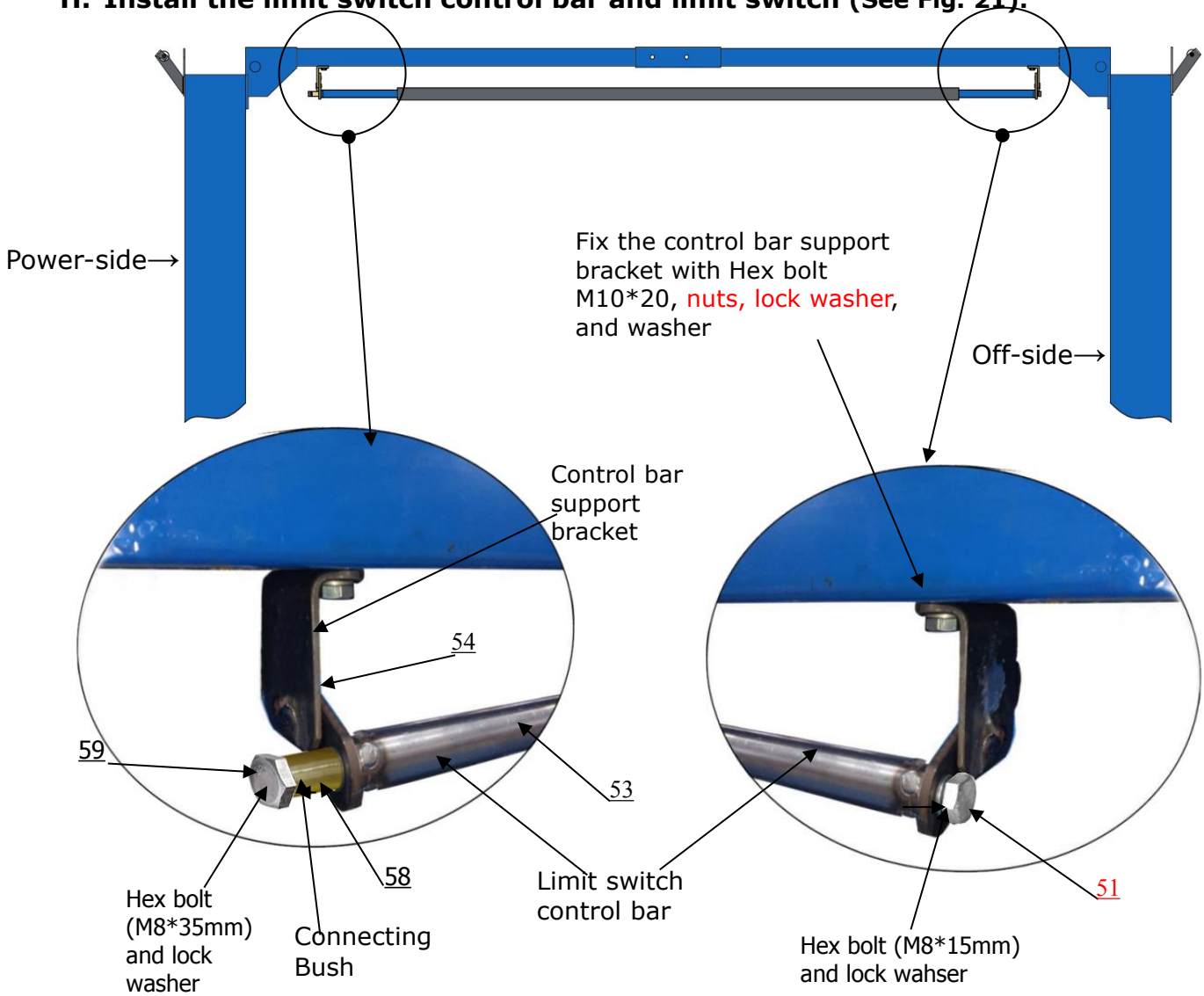

Fig.21

Installing the limit switch and wire.

1. Connect the wire:

Connect the red wire to terminal NC#, another side of the wire connect to the terminal A2 on AC contactor of power unit.

Connect the black wire to terminal C#, another side of the wire connect to the terminal 4 on control button of power unit.

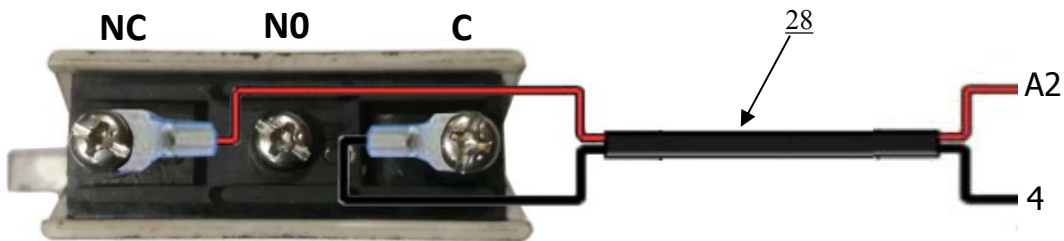

Wire of limit switch

Fig.22

2. Tighten limit switch. Fix the limit switch on control bar support bracket of the power-side as the photo. The wire pass through the top beam and connected to the AC contactor of power unit.

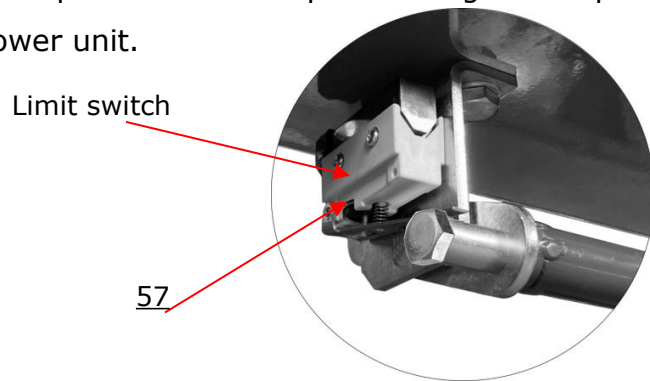
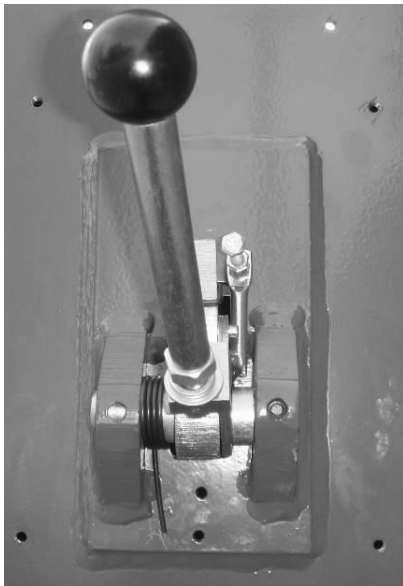
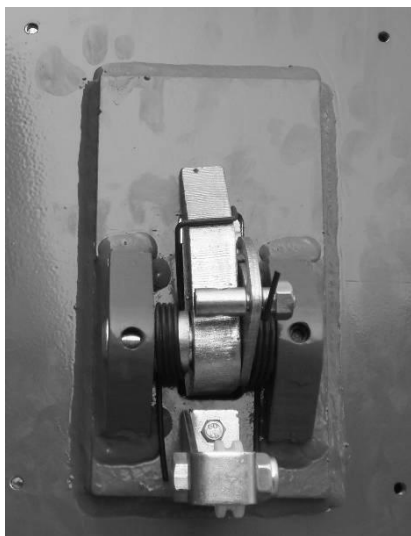
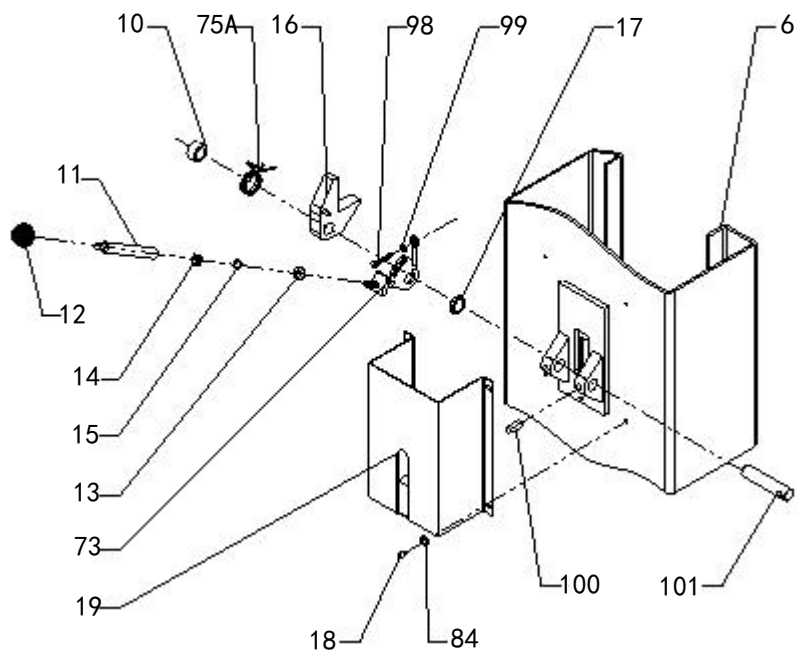

Fig.23

I. Install safety device (See Fig. 24 & Fig. 25).



**Power-side safety device
Fig.24**



**Offside safety device
Fig.25**

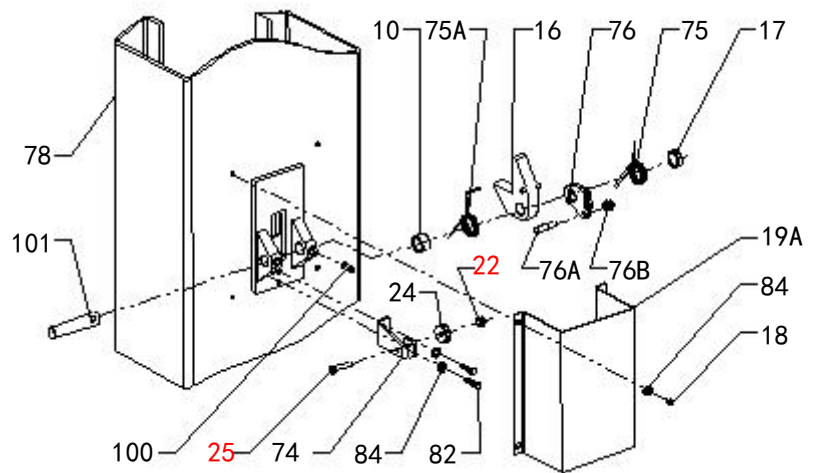

J. Install cables

Lift the carriages up and make them be locked at the same level

1. Low setting cable connection (**See Fig. 26**).

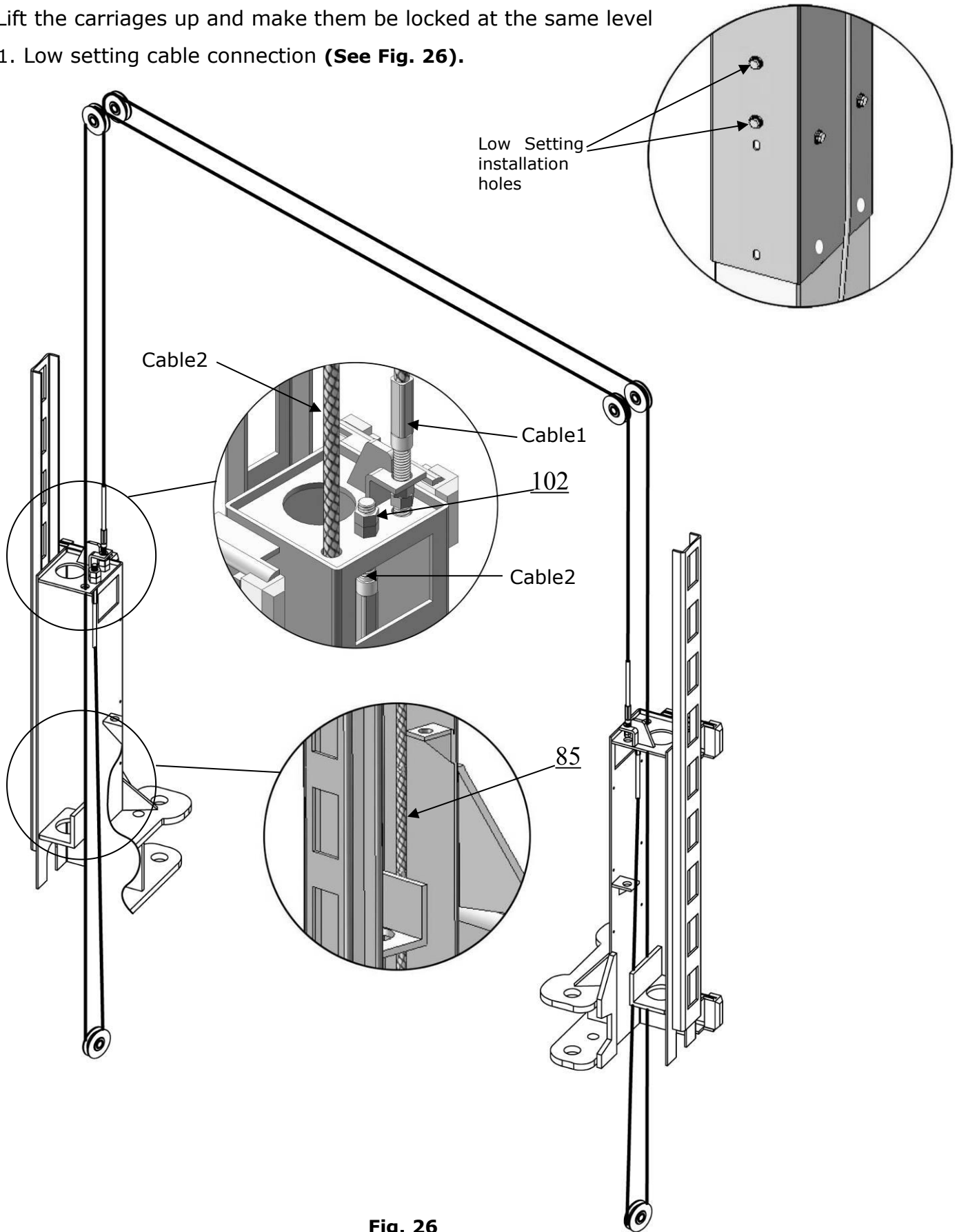

Fig. 26

2. High setting cable connection

2.1. Cable pass through from the bottom of the carriages and be pulled out from the open of carriages, then screw the two cable nuts (**See Fig. 27**).

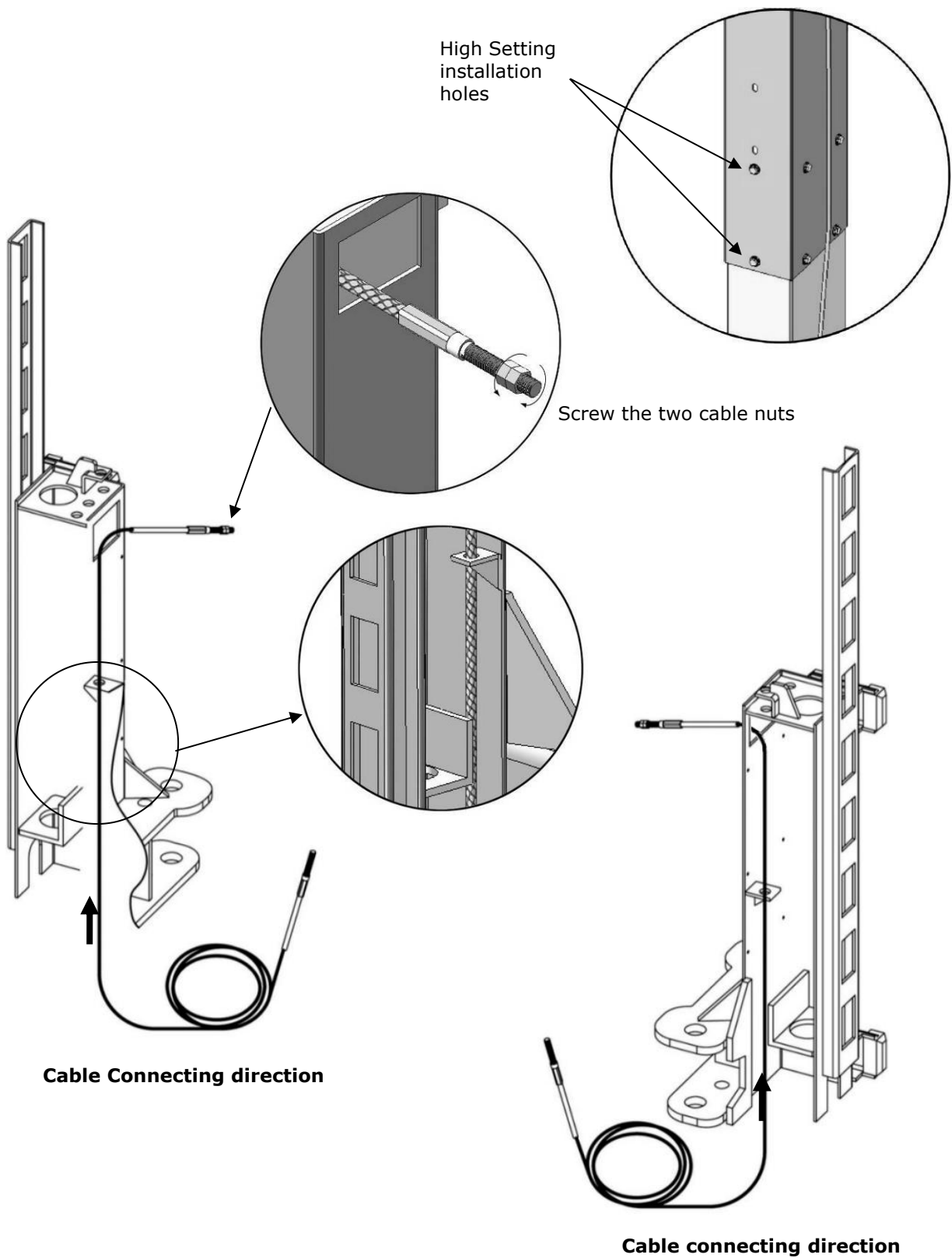

Fig. 27

2.2 Connecting cable for high setting (See Fig. 28).

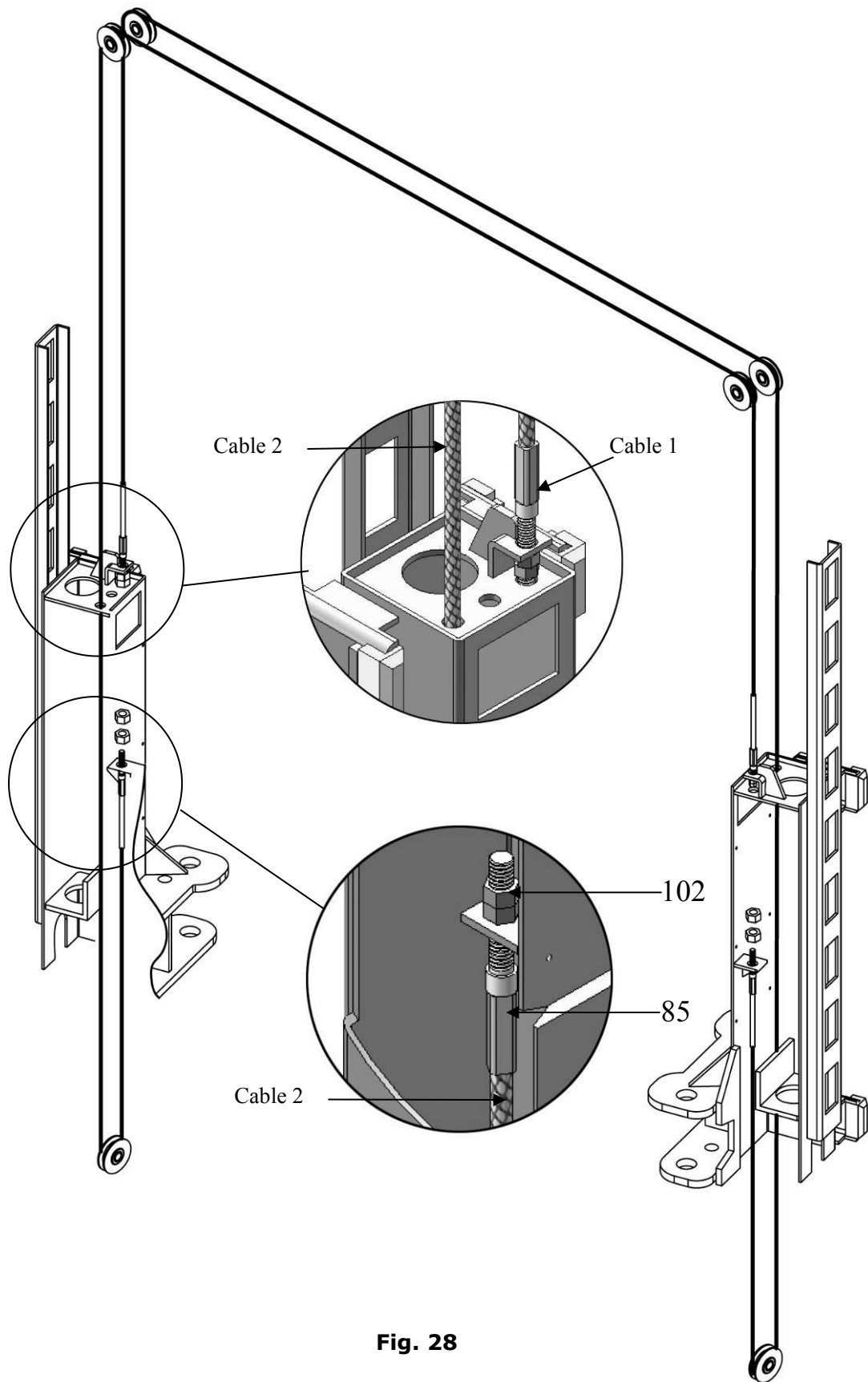

Fig. 28

K. Install oil hose.

1. Oil-line connecting drawing. **(See Fig.29)**

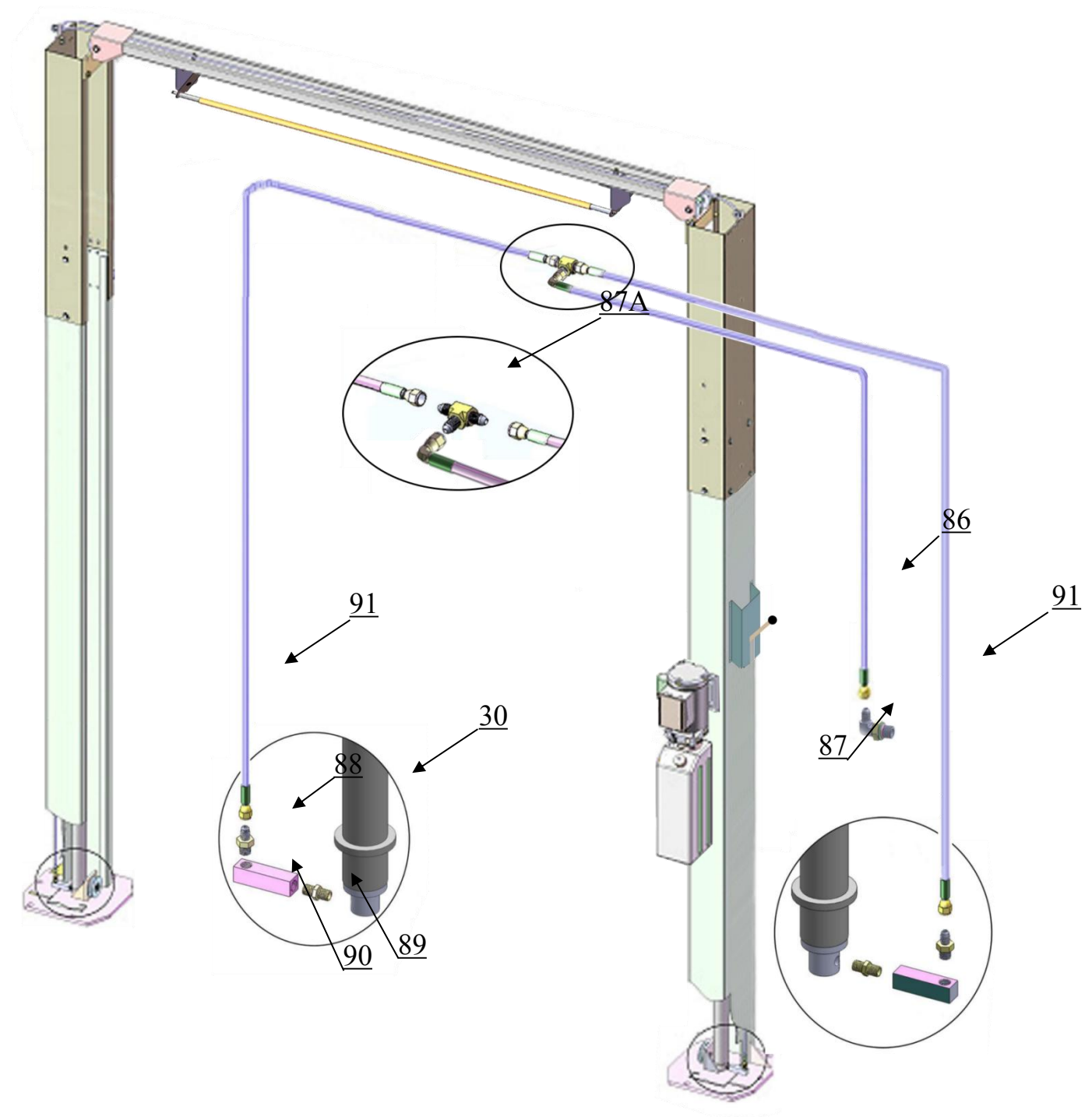

Fig.29

2. Follow these steps to connect the oil hose with power unit.

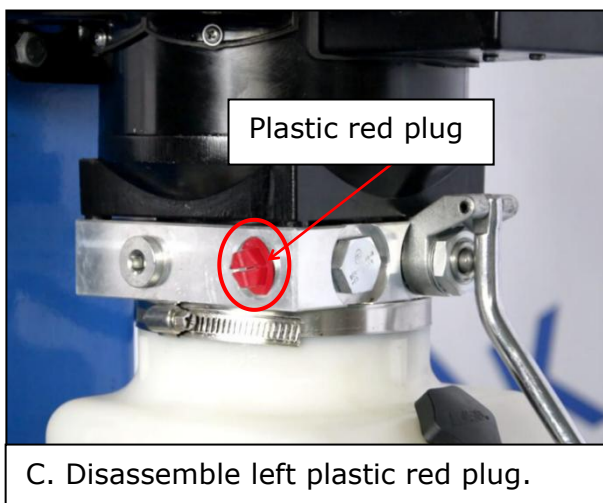
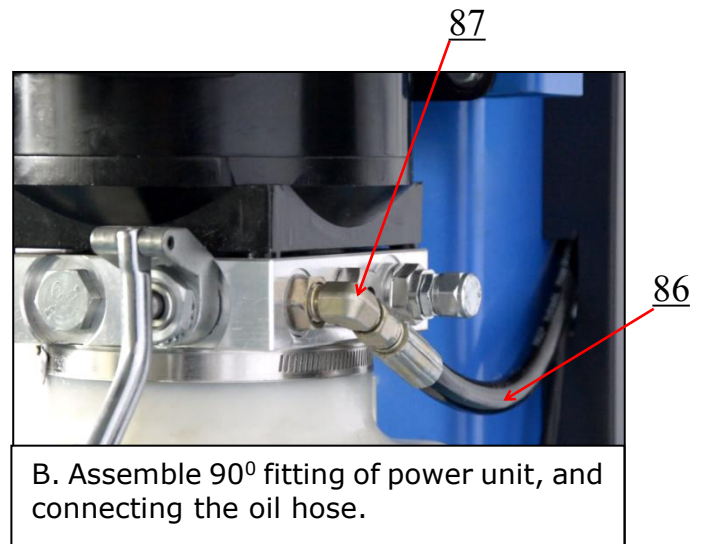
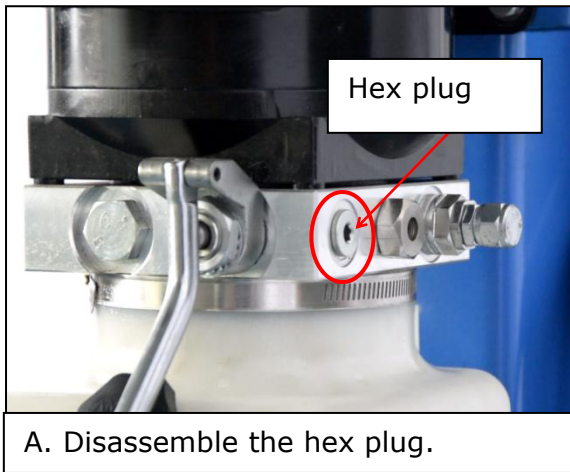
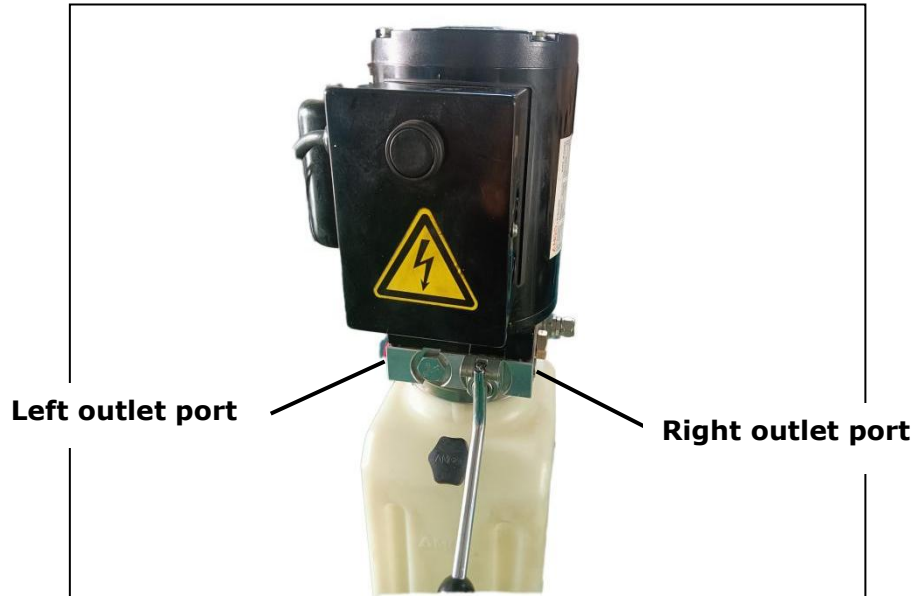

Fig.30

L. Install protective cover. (Fig.31)

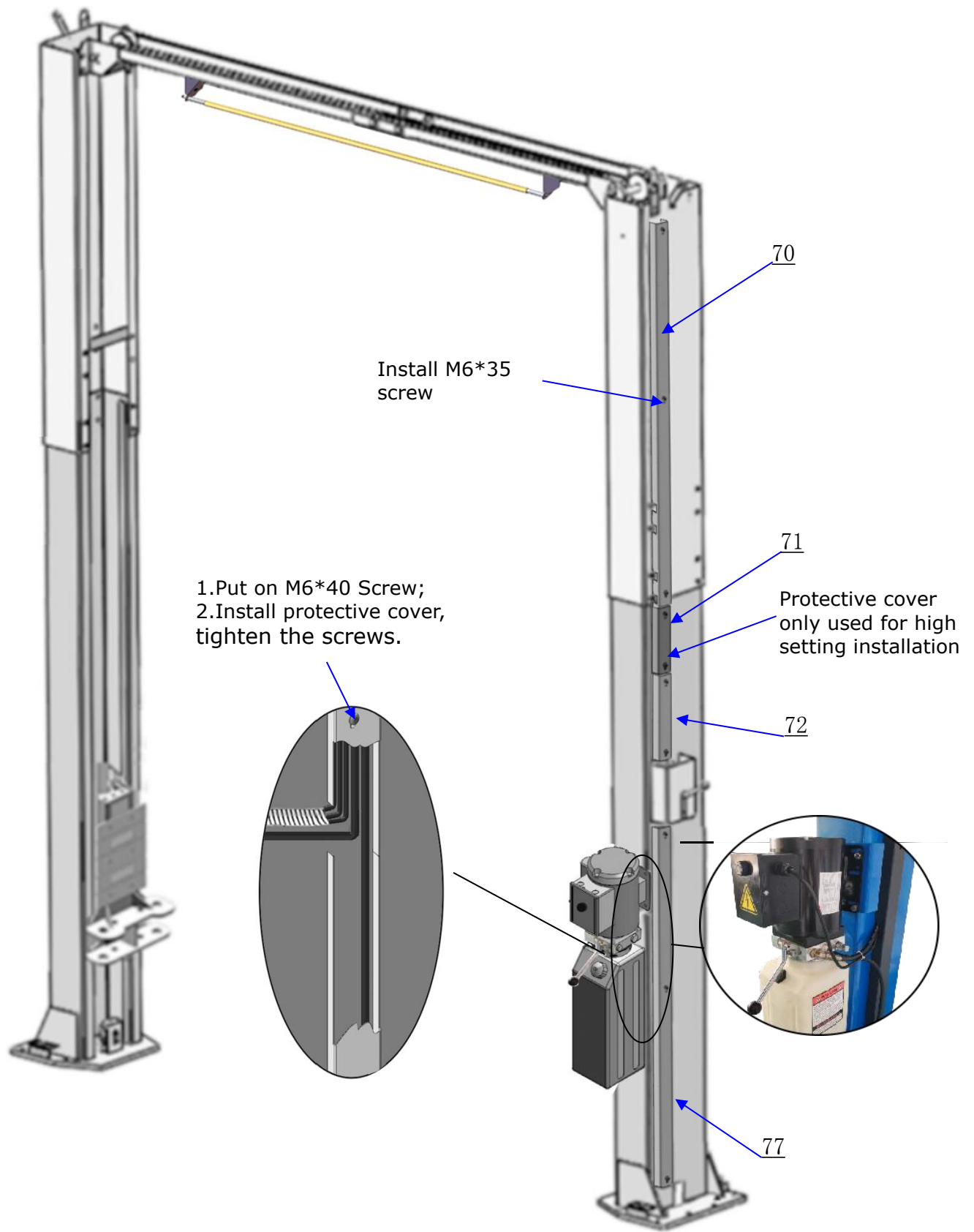
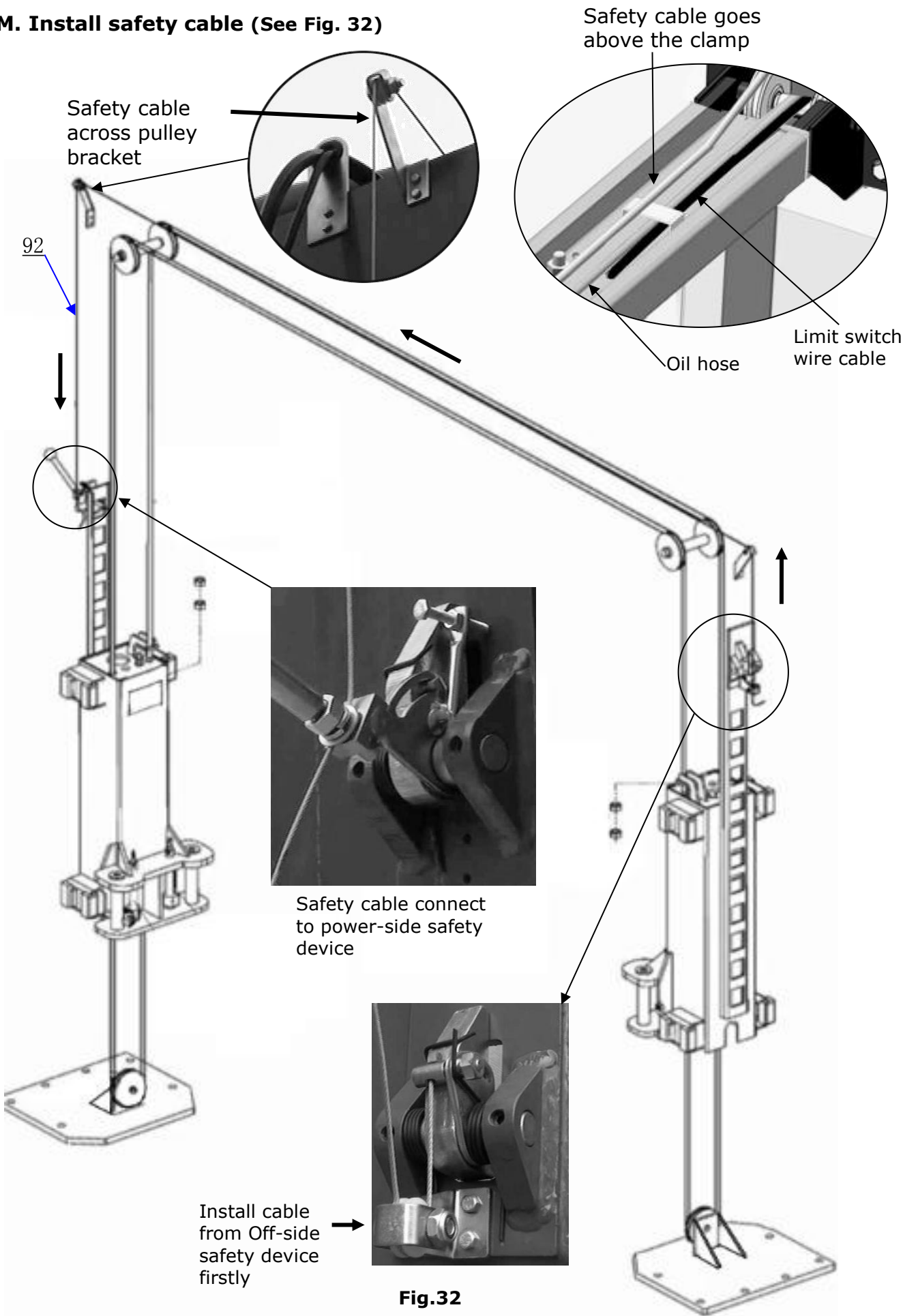
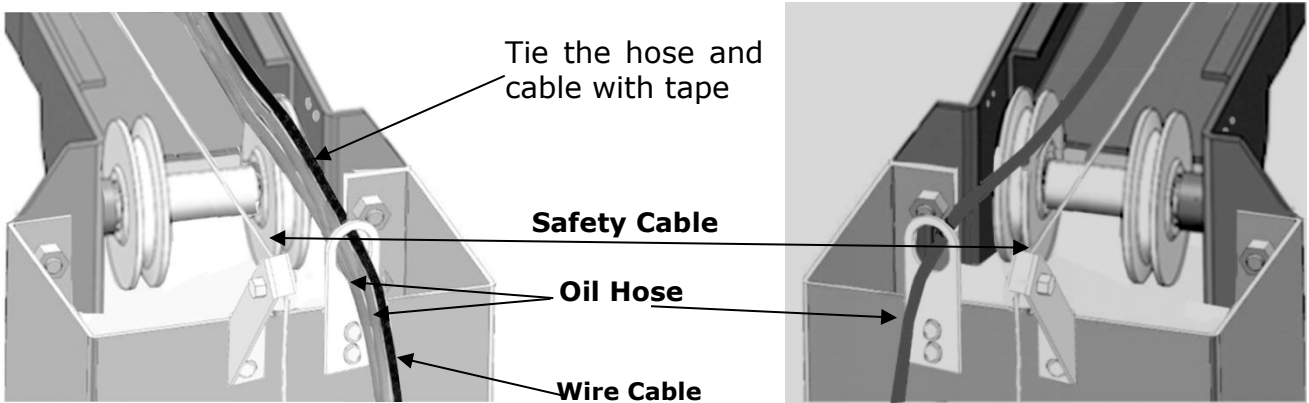

Fig.31

M. Install safety cable (See Fig. 32)



Note: Don't cross the oil hose and safety cable together (See Fig. 33 & Fig. 34).



**Power-side Safety Device
Fig. 33**

**Offside Safety Device
Fig. 34**

N. Install safety cable limit plate (See Fig. 35).

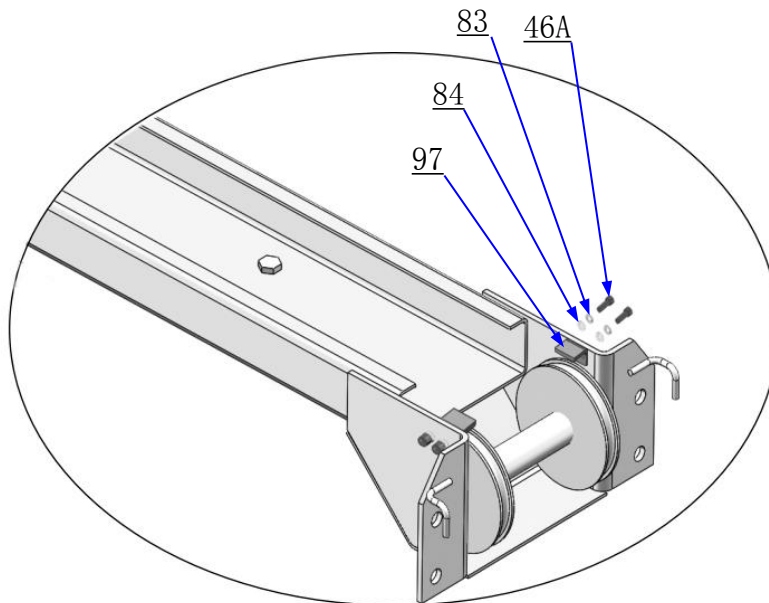

Fig. 35

O. Install lifting arms and adjust the arm locks.

1. Install the lifting arms (See Fig. 36).
2. Lowering the carriages down to the lowest position, then use the 8# socket head wrench to loose the socket bolt (See Fig. 37).

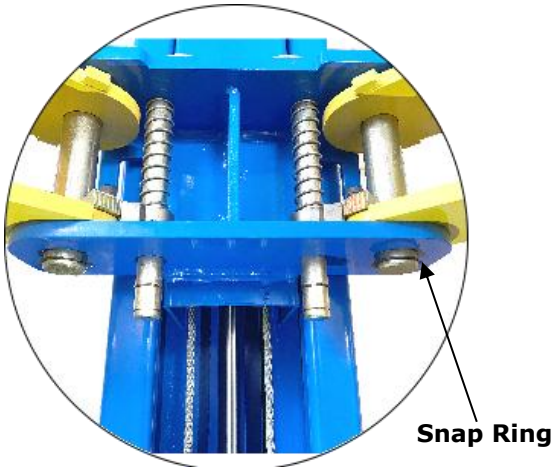

Fig. 36

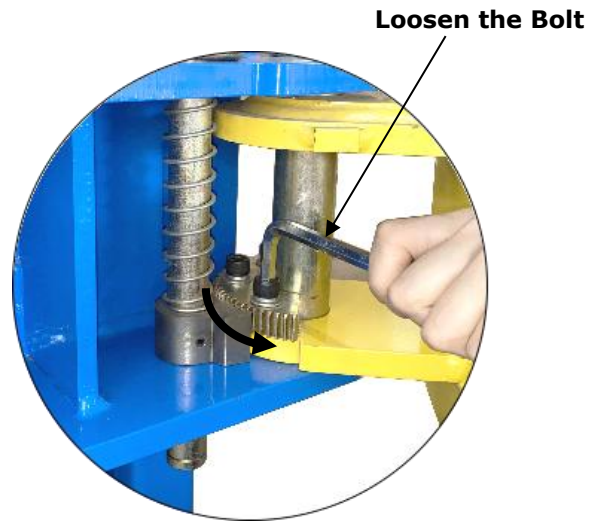
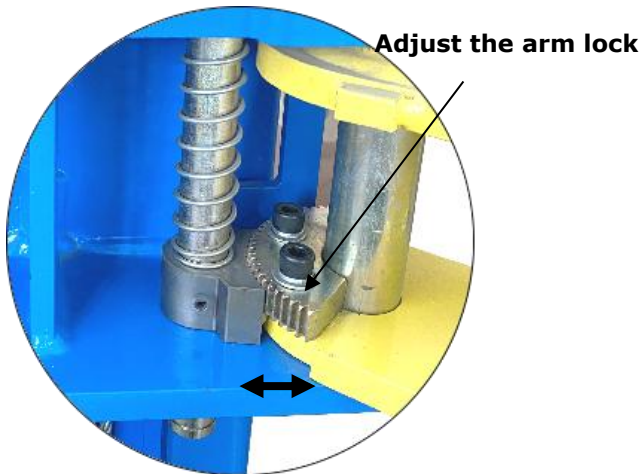

Fig. 37

Use the 8# Socket Head Wrench to loosen the Socket Bolt.

3. Adjust the arm lock.



Adjusting moon gear and arm lock to mesh.

Fig. 38

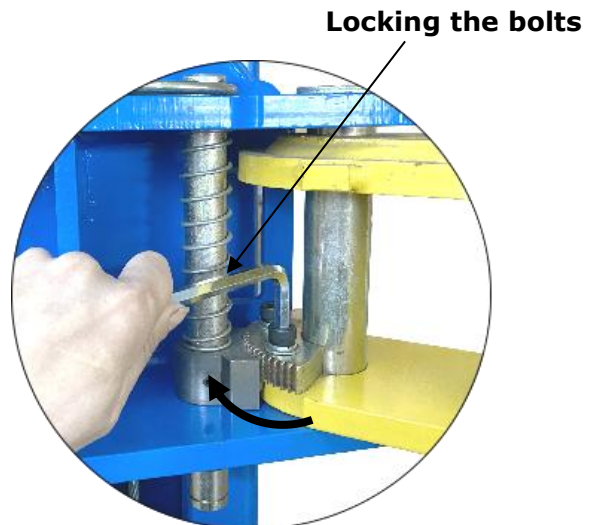

Fig. 39

Locking the bolts after the moon gear and arm lock engaged well.

P. Tighten all the hydraulic fittings, and fill the reservoir with hydraulic oil.

Note: In consideration of Hydraulic Power Unit's durability and keep the equipment running in the perfect condition, please use Hydraulic Oil 46#.

Q. Install electrical system

Connect the power source according to the nameplate of the motor.

Note: 1. Install the limit switch.

2. For the safety of operators, the lift must connect with the ground wire.

Single phase motor wiring (See Fig. 40)

- a. When power supply wires are active wire L and neutral wire N ,connecting active wire L to terminals of AC contactor marked L1, connecting neutral wire N to terminals of AC contractor marked L3.
 - b. When power supply wires are two active wire L ,connecting to terminals of AC contactor marked L1, L3 respectively.
 - c. Connecting the limit switch: Remove the short wire connecting terminal 4# of control button and A2 of AC contactor firstly (See Fig. 41), then connect wire C#(black wire) of limit switch with terminal 4# of control button and connecting wire NC#(red wire) with terminals A2 of AC contactor respectively. (See Fig. 42)
- The interior wire of limit switch connecting NC# and C#, refer to Step H.

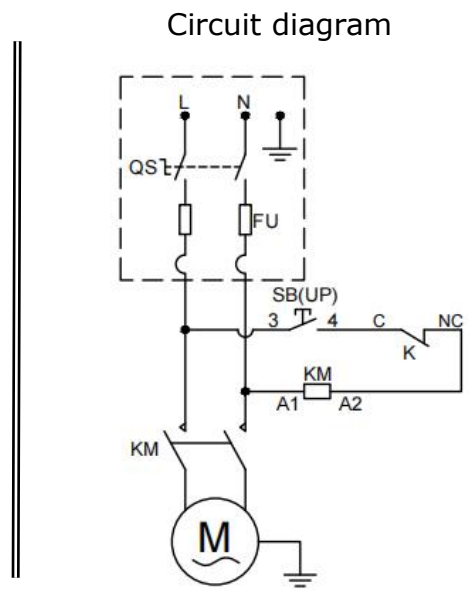
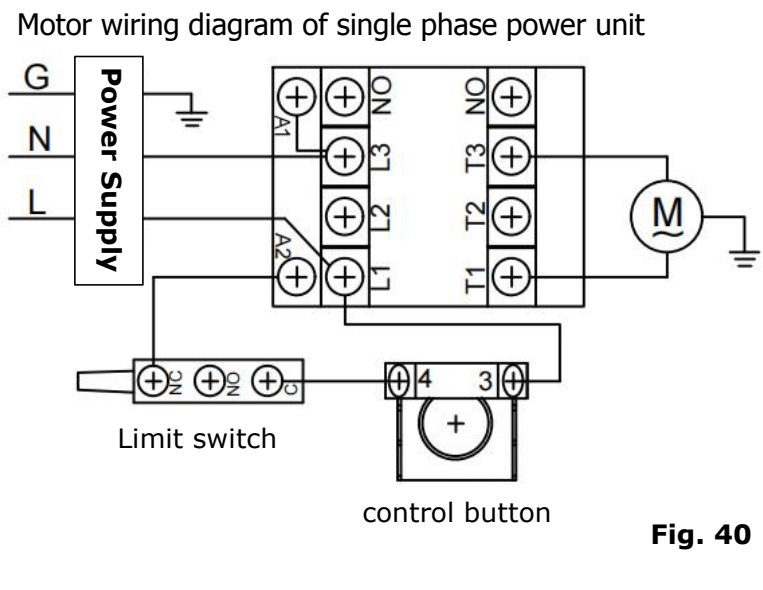

Fig. 40

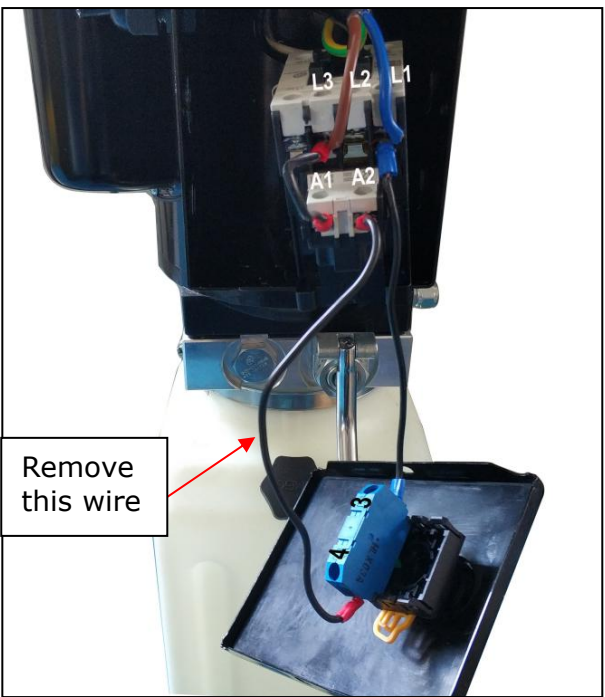

Fig. 41

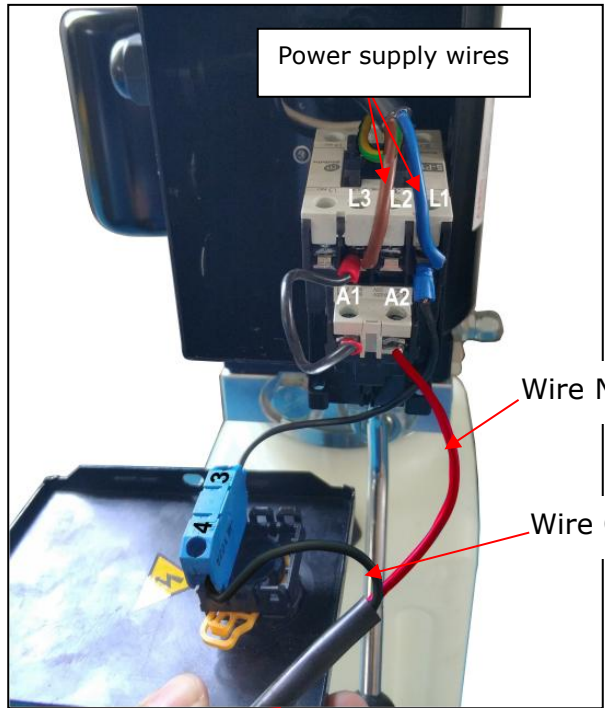

Fig.42

Limit switch wire

IV. EXPLODED VIEW

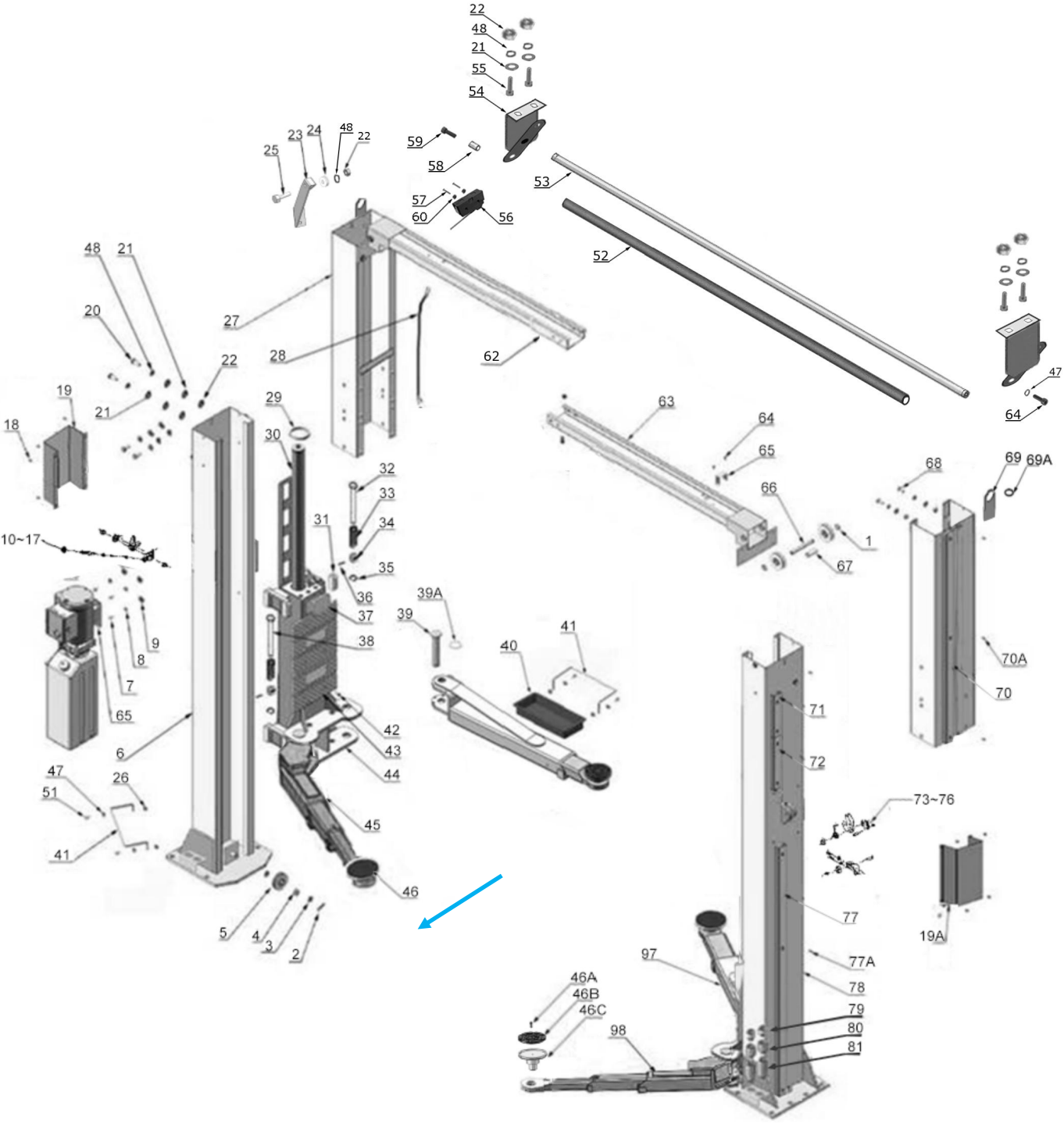

Fig. 43

PARTS LIST

Item	Part No.	Description	QTY.
1	10206019	Snap Ring ϕ 19	4
2	10209012	Elastic latch ϕ 3.2	2
3	10209128	Washer ϕ 20	4
4	1002011001	Bronzed bush for Pulley ϕ 22* ϕ 19*14	6
5	11020111001	Pulley ϕ 80* ϕ 22*15	6
6	11279023	Power-side Inner Column	1
7	10209003	Hex Bolt M8*25	8
8	10209004	Rubber Ring ϕ 8*20*3	4
9	10209005	Self-locking Nut M8	4
10	11217436	Safety device spacer ϕ 27*15	2
11	11217006	Safety device control stick	1
12	10217005	Plastic ball M10	1
13	10206023A	Hex bolt M12	15
14	10420026	Lock Washer ϕ 12	15
15	10206006	Washer ϕ 12	23
16	11217009	Safety device	1
17	11217012	Safety device spacer ϕ 27*10	2
18	10209009	Cap head screw M6*8	10
19	11217405	Cover for power-side safety device	1
19A	11217406	Cover for offside safety device	1
20	10209126	Hex Bolt M10*25	20
21	10209022	Washer ϕ 10	44
22	10209021	Hex Nut M10	24
23	11217379	Safety Cable Bracket	2
24	10206009	Plastic Pulley (white)	3
25	10209046	Hex bolt M6*20	3
26	10209033	Washer ϕ 8	12
27	11203221	Extension Column L=1240mm	2
28	10206137	Wire Cable L=3700	1
29	10209111	Protective Ring for Cylinder	2
30	1002216000	Cylinder ϕ 50*1727	2
31	10209015	Slider Block	16
32	11217046A	Arm Lock Bar (Left)	2
33	10206050A	Spring	4
34	10217044-01	Arm Lock	4
35	10206032	Snap Ring ϕ 25	4
36	10206036	Hair Pin ϕ 6*40	4
37	10209016	Carriage Plastic Cover	2
38	11217046	Arm Lock Bar (right)	2
39	11217168	Arm pin assy.	4
39A	10520023	Snap Ring ϕ 38	4
40	10206190	Tool tray (Short)	2
41	11206191	Toe guard bar	4
42	10209019	Screw M6*16	12

Item	Part No.	Description	QTY.
43	10209018	Protective Rubber	2
44	11279004	Carriage	2
45	1102214012C	Front right Arm	1
45A	1102214005C	Front left Arm	1
46	10201046A	Rubber pad assy.	4
46A	10420138	Socket bolt M6*16	12
46B	10209134	Rubber pad	4
46C	11680030C	Rubber pad bracket	4
47	10209034	Lock Washer φ8	15
48	10209039	Lock washer φ10	27
49	10209059	Anchor bolt 3/4*5-1/2	12
50	10206500B	Parts box	1
51	10201002	Hex Bolt M8*16	15
52	10206025A	Foam Cushion with handle	1
53	1102072001A	Control Bar φ22*2400	1
54	1103072003A	Control Bar Support Bracket	2
55	10206017	Hex Bolt M10*20	4
56	1002022001	Limit Switch CZ-7120	1
57	10420164	Cap Head Bolt M4*30	2
58	11207007	Connecting Bush φ14*2*20	1
59	10201122	Hex Bolt M8*35	1
60	10620095	Hex nut M4	2
62	11206195-01	Top Beam (Part A)	1
63	11206196-01	Top Beam (Part B)	1
65	071101	Power unit	1
66	11279016	Pin for Pulley	2
67	11206022	Top Pulley spacer	2
68	10206024	Hex Bolt M12*25	8
69	11217024	Oil hose retainer	2
69A	1061K074	Wire guard	2
70	11203752	Wire protective cover L=1140	2
70A	10206110	Cap head bolt M6*35	4
71	11279624	Protective Cover(L=200mm)	2
72	11203754-01	Protective Cover(L=385mm)	2
73	11217004	Active safety control block	1
74	11217029	Safety Pulley Bracket	1
75	10217008	Torsion spring φ2.5*145°	1
75A	10217030	Torsion spring φ2.0*120°	2
76	11217031	Driven safety control block	1
76A	10217032	Wire cable connecting pin	1
76B	11217033	Tension nut	1
77	10203778	Protective Cover L=1545	2
77A	10206079	Cap Head Bolt M6*40	14
78	11279024	Offside Inner column	1
79	11209051B	Stackable Adapter (1.5")	4

Item	Part No.	Description	QTY.
80	11209052B	Stackable Adapter (2.5")	4
81	11209053B	Stackable Adapter (5")	4
82	10217066	Anchor Bolt M6*15	10
83	10209149	Lock Washer φ6	18
84	10420045	Washer φ6	26
85	10206064A	Cable L=10048mm	2
86	10206132-01	Oil hose L=4470mm	1
87	10209060	90° fitting for power unit	1
87A	10211016	T fitting	1
88	10209064	Straight Fitting	2
89	10206062	Straight Fitting	2
90	10233009	Oil hose straight fitting(square)	2
91	10206130-01	Oil Hose L=5350mm	2
92	10260149	Safety cable L=7750mm	1
93	10209066	Hex nut M16	8
94	10201090	Shim (1mm)	10
	10620065	Shim (2mm)	10
95	10209152	Ties 3*150mm	4
96	1102214001C	Rear Arm assy.	2
97	1102075001	Cable limit plate	4
98	10217010	Hex bolt M6*40	1
99	10217011	Hex nut M6	9
100	10217051	Socket bolt M10*10	2
101	11217050	Safety device pin	2
102	10209066	Nut M16	8

4.1 Rear arm assy. (1102214001C) explosive view

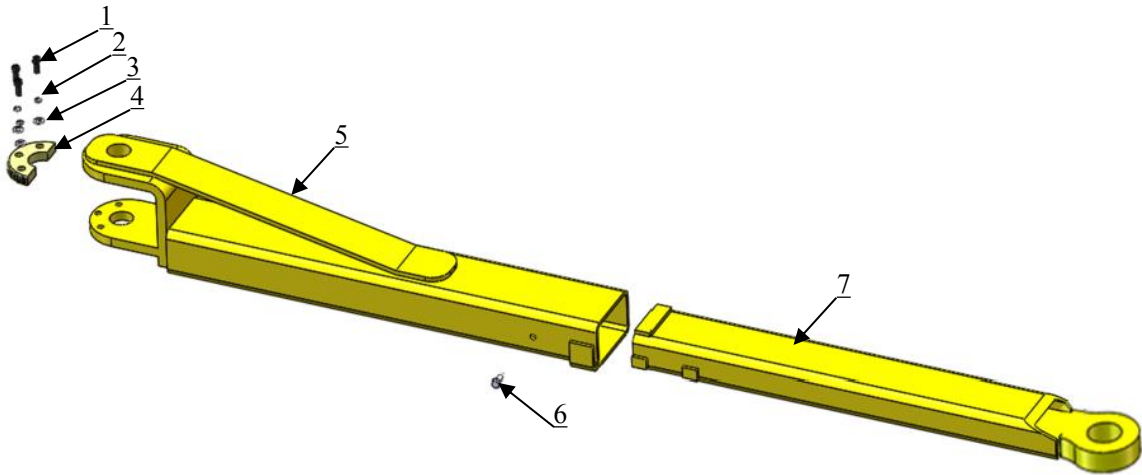

Fig.44

Item	Part No.	Description	QTY.
1	10206048	Socket bolt M10*30	6
2	10209039	Lock Washer φ10	6
3	10209022	Washer φ10	6
4	11206049	Moon gear	2
5	1102214001A	Rear outer arm	2
6	10201149	Cap head bolt M8*12	2
7	1102214004A	Rear inner arm	2

4.2 Left front arm assy. (1102214005C) explosive view

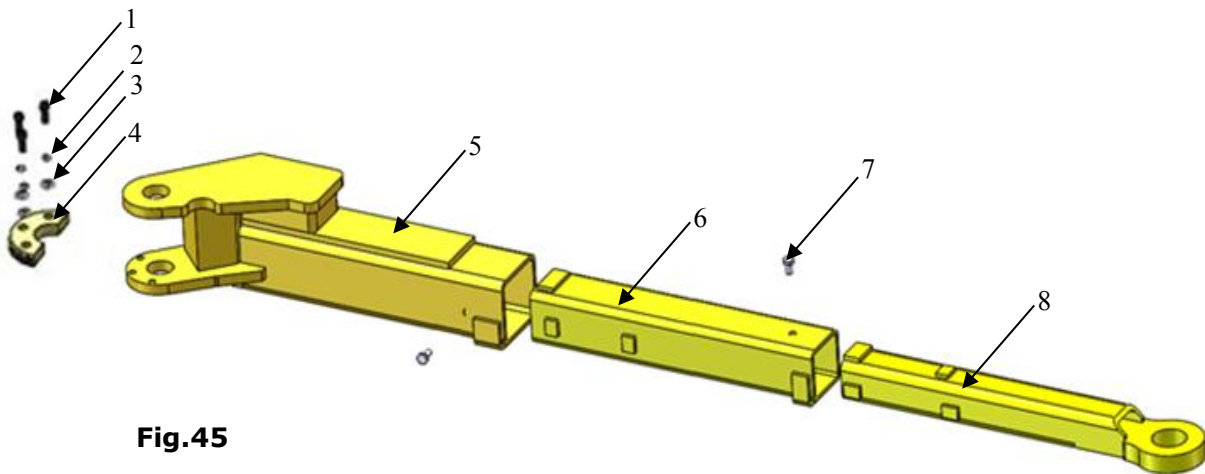

Fig.45

Item	Part No.	Description	QTY.
1	10206048	Socket bolts M10*30	3
2	10209039	Lock Washer φ10	3
3	10209022	Washer φ10	3
4	11206049	Moon gear	1
5	1102214005A	Outer arm- Left front	1
6	1102214009A	Middle arm - Front	1
7	10201149	Cap head bolt M8*12	2
8	1102214010A	Inner arm - Front	1

4.3 Right front arm assy. (1102214012C) explosive view

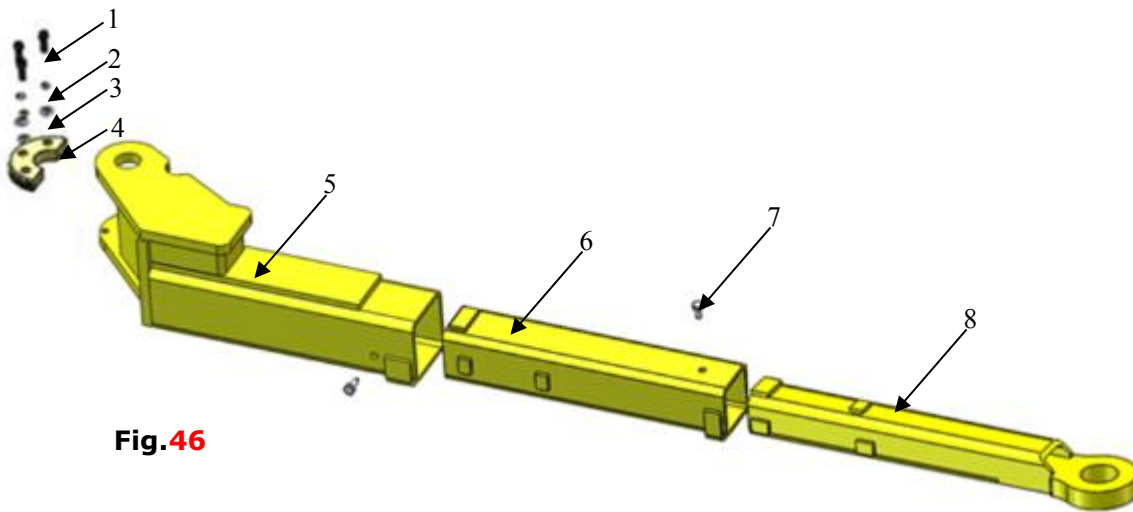

Fig.46

Item	Part No.	Description	QTY.
1	10206048	Socket bolt M10*30	3
2	10209039	Lock Washer φ10	3
3	10209022	Washer φ10	3
4	11206049	Moon gear	1
5	1102214012A	Outer arm -Right front	1
6	1102214009A	Middle arm - front	1
7	10201149	Cap head bolt M8*12	2
8	1102214010A	Inner arm- Front	1

4.4 Cylinder (1002216000) explosive view

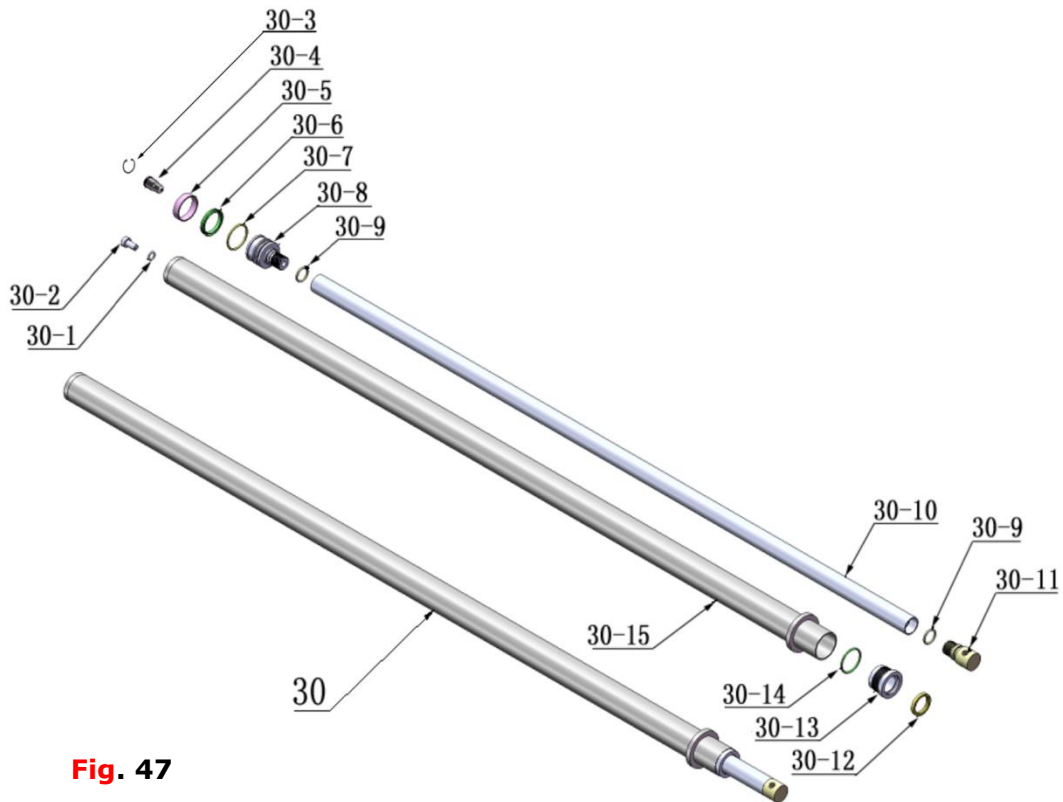

Fig. 47

Part list of cylinder

Item	Part No.	Description	QTY.
30-1	10209069	O-ring	2
30-2	10209070	Bleeding Plug	2
30-3	1002576003	Support Ring	1
30-4	11720114	Pressure Compensated Flow Restrictor (0.7 Spring)	1
30-5	10209071	Wear ring	2
30-6	10209072	Y-ring OSI	2
30-7	10209073	O-Ring	2
30-8	1102576005	Piston	2
30-9	10209075	Piston Rod Fitting	2
30-10	11217076	Piston rod	2
30-11	11209077	Piston Rod Fitting	2
30-12	10209078	Dust wing	2
30-13	11209079	cover	2
30-14	10209080	O ring	2
30-15	11209081A	Cylinder components	2

4.5 Power unit (071101) explosive view

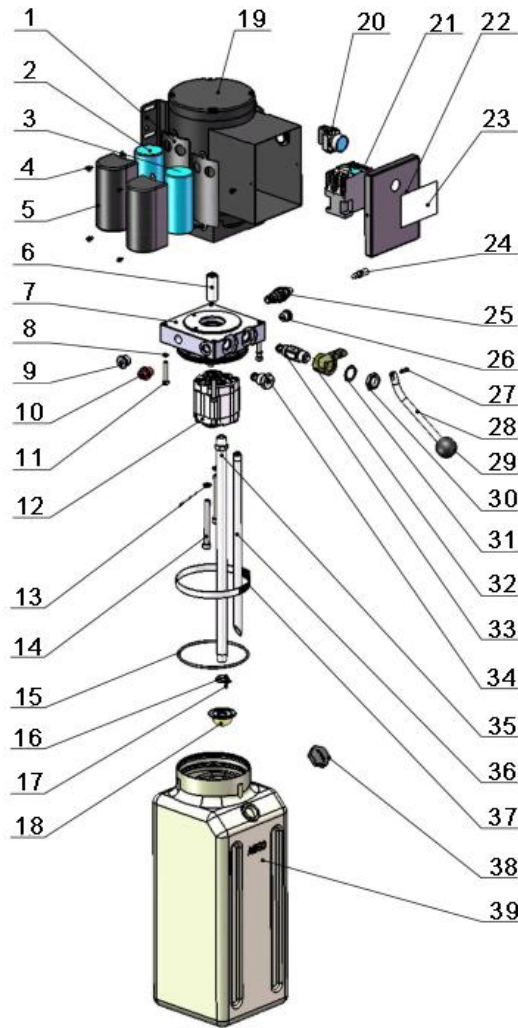
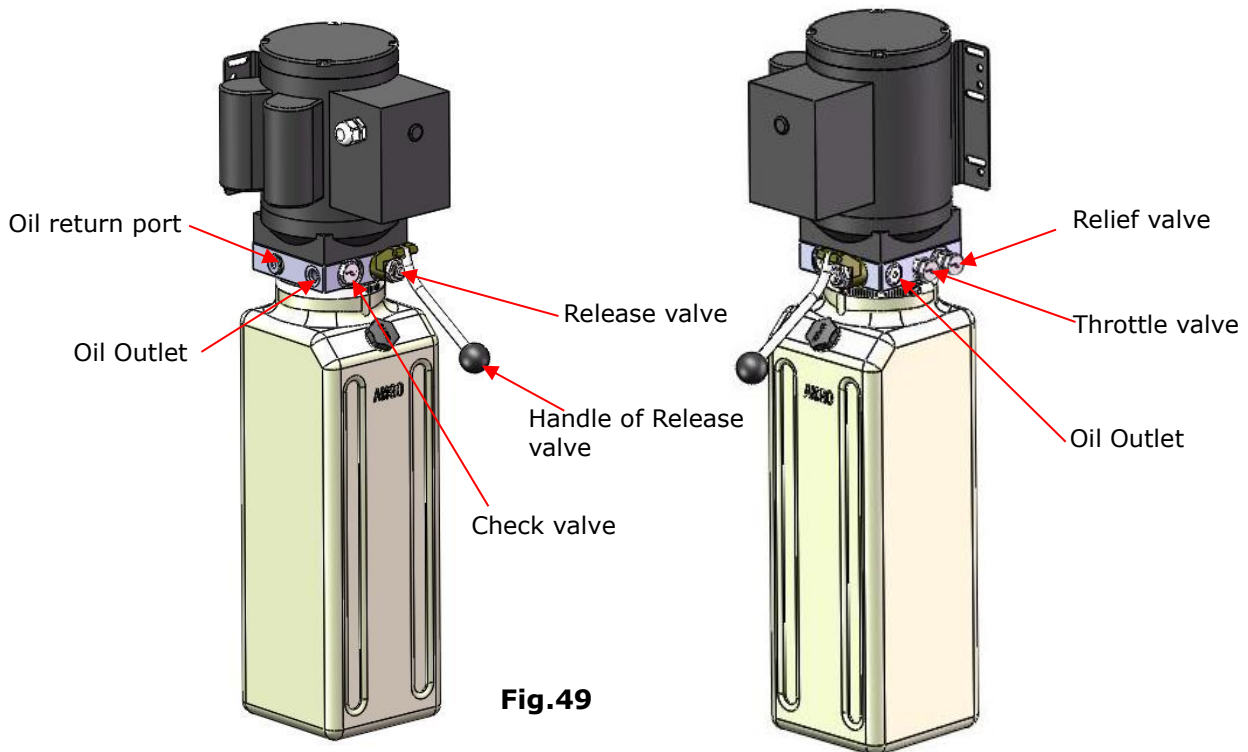

Fig. 48
Single phase 220V/60HZ

Part list of power unit (220V/60HZ/single phase)

Item	Part No.	Description	QTY.	Item	Part No.	Description	QTY.
1	81400180	Rubber pad	2	21	41030055	AC contractor	1
2	81400250	Starting capacitor	1	22	81400287	Motor wiring cover	1
3	81400200	Running capacitor	1	23	71111104	AMGO label	1
4	10420148	Screw with washer	4	24	81400560	Throttle valve	1
5	81400527	Capacitor cover	2	25	81400266	Relief valve	1
6	81400363	Motor connector	1	26	81400284	Plug	1
7	80101013	Manifold block	1	27	10720118	Elastic pin	1
8	10209149	Washer	4	28	81400451	Release handle	1
9	81400276	Iron Plug	1	29	10209020	Plastic ball for handle	1
10	81400259	Red rubber plug	1	30	81400421	Release valve nut	1
11	85090142	Hex bolt	4	31	81400422	Self-locking washer	1
12	81400280	Gear pump	1	32	81400449	valve seat(short)	1
13	10209034	washer	2	33	81400567	Release valve	1
14	81400295	Hex nut	2	34	81400566	Check valve	1
15	81400365	O-ring	1	35	81400288	Oil suction hose	1
16	10209152	Ties	1	36	81400289	Oil return hose	1
17	85090167	Magnet	1	37	81400364	Clamp(stainless steel)	1
18	81400290	Filter	1	38	81400263	Oil tank cap	1
19	81400413	Motor	1	39	81400275	Oil tank	1
20	10420070	Button switch	1				

4.6 Illustration of hydraulic valve for hydraulic power unit



V. TEST RUN

1. Adjustment of synchronous cable (See Fig. 50)

Use wrench to hold the cable fitting, meanwhile using ratchet spanner to tighten the cable nut until the two cables are in the same tension.

If the two vehicle carriages do not Synchronized when lifting and lowering, please screw and tighten the cable nut on the lower side carriage.

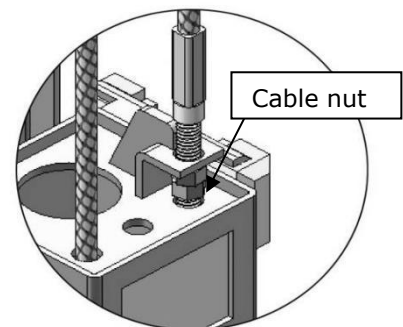

2. Adjust safety cable

Rise the vehicle carriages and lock them at the same height, strain the safety cable and then release a little, and then tighten the safety cable nuts. Make sure the safety device can always lock the carriages properly.

At last, install the plastic cover of the safety device.

3. Exhaust air from cylinder

This hydraulic system is designed to bleeding air by losing the bleeding plug. Lifting the carriages to about 1 meter height, and loose the bleeding plug, the air would be bled automatically, then tighten the plug after bleeding, the lift would work stably and smoothly, otherwise repeat bleeding (**See Fig. 51**).

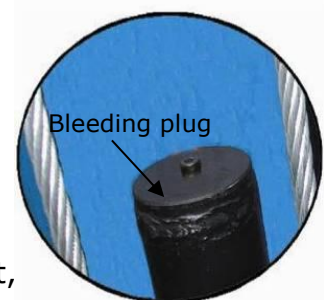

4. Adjust the lowering speed

You can adjust the lowering speed of the lift if needing: screw the throttle valve clockwise to decrease the lowering speed, or counterclockwise to increase the lowering speed.

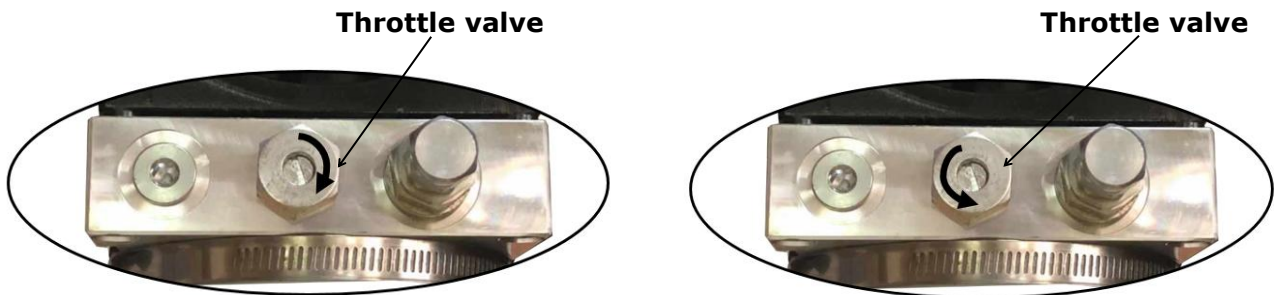

Adjust clockwise, decrease lowering speed

Counterclockwise, increase lowering speed

Fig. 52

5. Test with load

After finishing the above adjustment, test running the lift with load. Run the lift in low position for several times firstly, make sure the lift can rise and lower synchronously, the Safety Device can lock and release synchronously. And then test run the lift to the top completely. If there are anything improper, repeat the above adjustment.

NOTE: It may be vibrated when lifting at start, please lifting it with load for several times, the air would be bled and the vibration would be disappeared automatically.

Hydraulic System

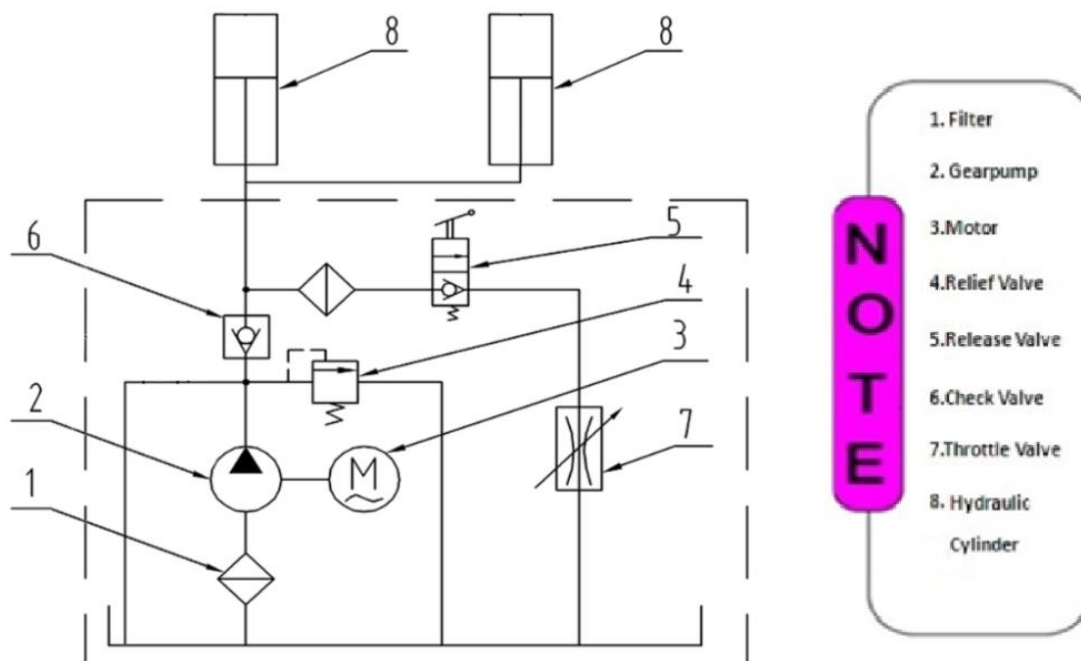

Fig.53

VI. OPERATION INSTRUCTIONS

Please read the safety notes carefully before operating the lift

To lift vehicle

1. Keep clean of site near the lift;
2. Position lift arms to the lowest position;
3. To shortest lift arms;
4. Open lift arms;
5. Position vehicle between columns;
6. Move arms to the vehicle's lifting point;

Note: The four lift arms must contact the vehicle's lifting point at the same time where manufacturers recommended

7. Push button **UP** until the lift pads contact underside of vehicle totally. Recheck to make sure vehicle is secure;
8. Continue to raise the lift slowly to the desired working height, ensuring the balance of vehicle;
9. Push release handle to lower lift onto the nearest safety. The vehicle is ready to repair.

To lower vehicle

1. Be sure clear of around and under the lift, only leaving operator in lift area;
2. Push button **UP** to raise the vehicle slightly, and then release the safety device, lower vehicle by pushing release handle.
3. Open the arms and position them to the shortest length;
4. Drive away the vehicle.
5. Turn off the power.

Note: In order to extend the service life of the cylinder and seals, raise the machine to top at least once a day

VII. MAINTENANCE SCHEDULE

Monthly:

1. Re-torque the anchor bolts with 150 N·M;
2. Check all connectors, bolts and pins to insure proper mounting;
3. Lubricate cable with lubricant;
4. Make a visual inspection of all hydraulic hoses/lines for possible wear or leakage;
5. Check Safety device and make sure proper condition;
6. Lubricate all Rollers and Pins with 90wt. Gear oil or equivalent;

Note: All anchor bolts should take full torque. If any of the bolts is malfunction for any reason, DO NOT use the lift until the bolt has been replaced.

Every six months:

1. Make a visual inspection of all moving parts for possible wear, interference or damage.
2. Check and adjust as necessary, equalizer tension of the cables to insure level lifting.
3. Check columns for plumbness.
4. Check Rubber Pads and replace as necessary.
5. Check Safety device and make sure in proper condition.

Oil cylinder maintenance:

In order to extend the service life of the oil cylinder, please operate according to the following requirements.

1. Recommend to use N46 anti-wear hydraulic oil.
2. The hydraulic oil of the lifts should be replaced regularly during using. Replace the hydraulic oil 3 months after the first installation, Replace the hydraulic oil once a year afterwards.
3. Make at least one full trip raising and lowering per day. For exhausting the air from the system, which could effectively avoid the corrosion of the cylinder and damage to the seals caused by presence of air or water in the system.
4. Protect the outer surface of the oil cylinder's piston rod from bumping and scratching, and timely clean up the debris on the oil cylinder dust-ring and the piston rod.

VIII.TROUBLE SHOOTING

TROUBLE	CAUSE	REMEDY
Motor does not run	<ol style="list-style-type: none"> 1. Button does not work 2. Wiring connections are not in good condition 3. Motor burned out 4. Height Limit Switch is damaged 5. AC contactor burned out 	<ol style="list-style-type: none"> 1. Replace button 2.Repair all wiring connections 3. Repair or replace motor 4. Replace the Limit Switch 5. Replace AC Contactor
Motor runs but the lift is not raised	<ol style="list-style-type: none"> 1. Motor runs in reverse rotation 2. Gear Pump out of operation 3. Release Valve in damage 4. Relief Valve or Check Valve in damage 5. Low oil level 	<ol style="list-style-type: none"> 1.Reverse two power wire 2.Repair or replace 3. Repair or replace 4.Repair or replace 5.Fill tank
TROUBLE	CAUSE	REMEDY
Lift does not stay up	<ol style="list-style-type: none"> 1. Release Valve out of work 2. Relief Valve or Check Valve leakage 3. Cylinder or Fittings leaks 	Repair or replace
Lift raises too slow	<ol style="list-style-type: none"> 1. Oil line is jammed 2. Motor running on low voltage 3. Oil mixed with air 4. Gear Pump leaks 5. Overload lifting 	<ol style="list-style-type: none"> 1. Clean the oil line 2. Check Electrical System 3. Fill tank 4. Replace Pump 5. Check load
Lift cannot lower	<ol style="list-style-type: none"> 1. Safety device are in activated 2. Release Valve in damage 3. Safety cable broken 4. Oil system is jammed 	<ol style="list-style-type: none"> 1. Release the safeties 2. Repair or replace 3. Replace 4. Clean the oil system

IX. Lift disposal.

When the car lift cannot meet the requirements for normal use and needs to be disposed, it should follow local laws and regulations.



AMGO HYDRAULIC CORPORATION

1931 Joe Rogers Blvd, Manning, South Carolina,
Zip: 29102

Tel: (803) 505-6410

Fax: (803) 505-6410

Manual No.: 72228703

Revised date: 2022/10