

AMGO  [®] **Hydraulics**

Original

Installation And Service Manual

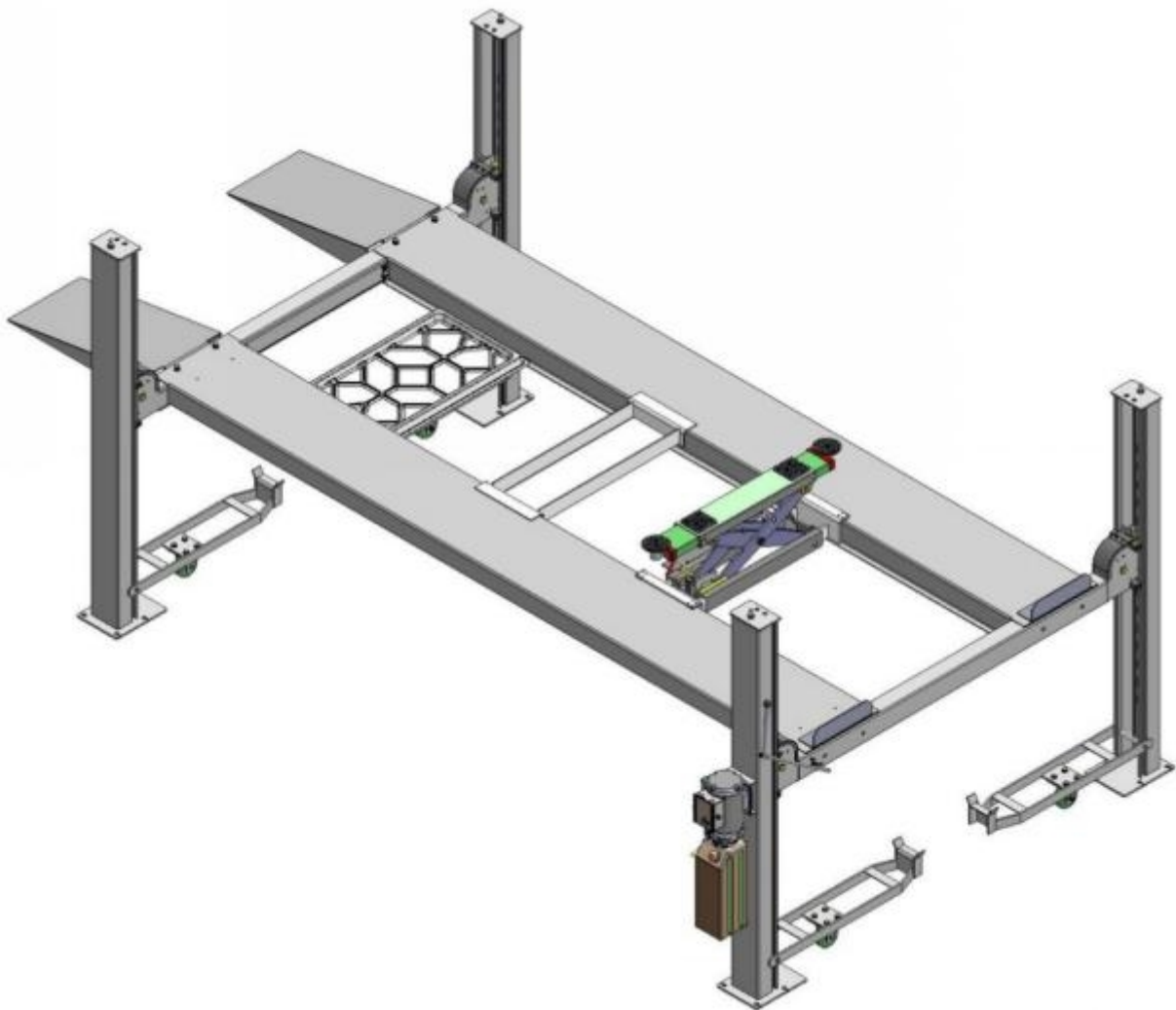

Four-Post Lift

Model: 408-P

CONTENTS

Product Features and Specifications	1
Installation Requirement	2
Steps of Installation	4
Exploded View	24
Test Run	31
Operation Instruction	32
Maintenance	33
Trouble Shooting	34
Scarping of equipment.....	34

I. PRODUCT FEATURES AND SPECIFICATIONS

4-POST MODEL 408-P FEATURES

- Single point manual safety release.
- Four mechanical locking devices, each equipped with both primary and secondly safety locks.
- Power-side column can be installed at both side, front or rear.
- Non-skid diamond platforms and adjustable safety lock ladders.
- Optional kits: Sliding jack with hand pump, caster kits, Jack tray, plastic oil tray.

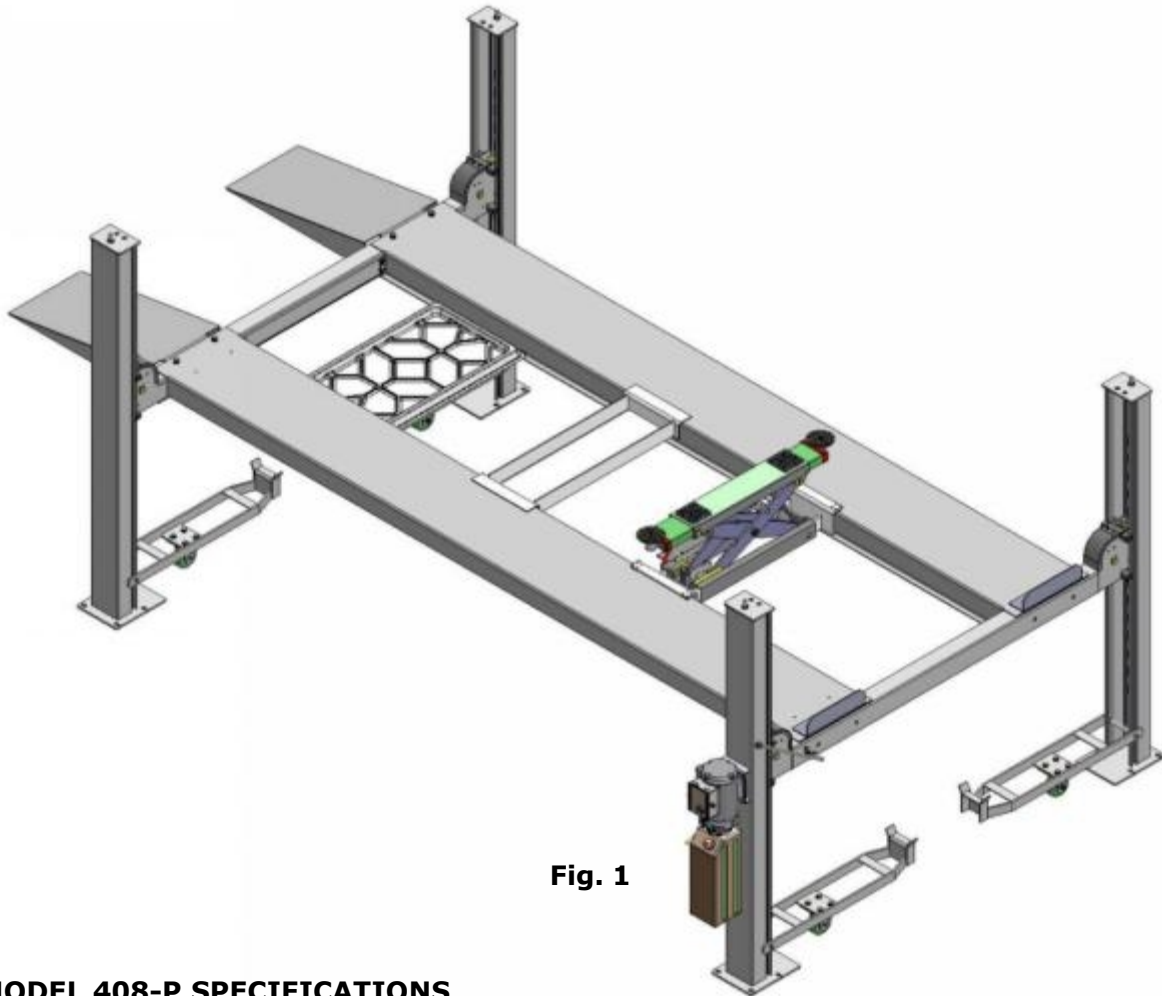

Fig. 1

MODEL 408-P SPECIFICATIONS

Model	Lifting Capacity	Lifting Height	Lifting Time	Overall Length (Inc. Ramps)	Overall Width	Width Between Columns	Motor
408-P	3500KG (8,000 lbs)	1872mm (73 3/4")	40S	5257mm (207")	2784mm (109 5/8")	2438mm (96")	220V: 2.0HP

II. INSTALLATION REQUIREMENT

A. TOOLS REQUIRED

- ✓ Tape Measure (7.5m)



- ✓ Hammer



- ✓ Level Bar



- ✓ English Spanner (12")



- ✓ Wrench set
(12#, 13#, 14#, 15#, 17#, 19#, 24#, 30#)



- ✓ Carpenter's Chalk



- ✓ Screw Sets



- ✓ Pliers



- ✓ Lock Wrench



- ✓ Socket Head Wrench
(3#, 5#, 6#, 8#)



Fig. 2

B. Equipment storage and installation requirements.

The equipment should be stored or installed in a shady, normal temperature, ventilated and dry place.

C. The equipment should be unload and transfer by forklift.



Fig.3

D.SPECIFICATIONS OF CONCRETE (See Fig. 4)

Specifications of concrete must be adhered to the specification as following.

Failure to do so may result in lift and/or vehicle falling.

1. Concrete must be thickness 150mm(5 7/8") minimum and without reinforcing steel bars, and must be dried completely before lift installation.
2. Concrete must be in good condition and must be of test strength 210kg/cm² (3,000psi) minimum.
3. Floors must be level and no cracks.

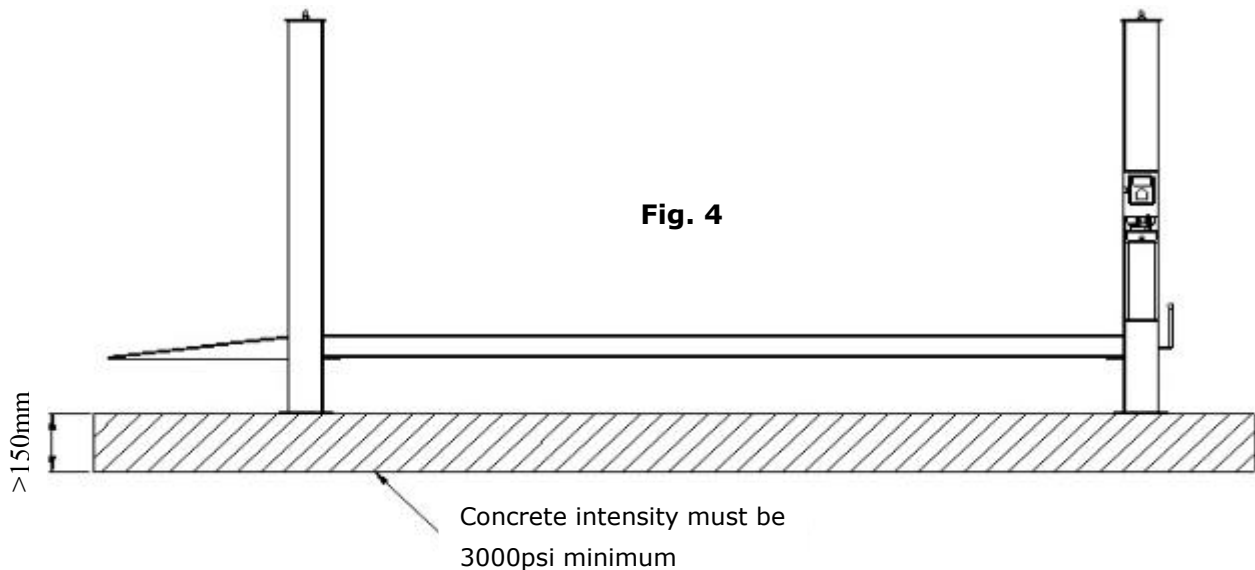

E. POWER SUPPLY

The electrical source must be 2HP minimum. The source cable size must be 2.5mm² minimum and in good condition of contacting with floor.

III. STEPS OF INSTALLATION

A. Check the parts before assembly

1. Packaged lift and Hydraulic Power Unit (See Fig. 5).



Fig. 5

Optional Plastic oil tray

2. Open the outer packing carefully, check the parts according to the shipment list. (See Fig. 6)

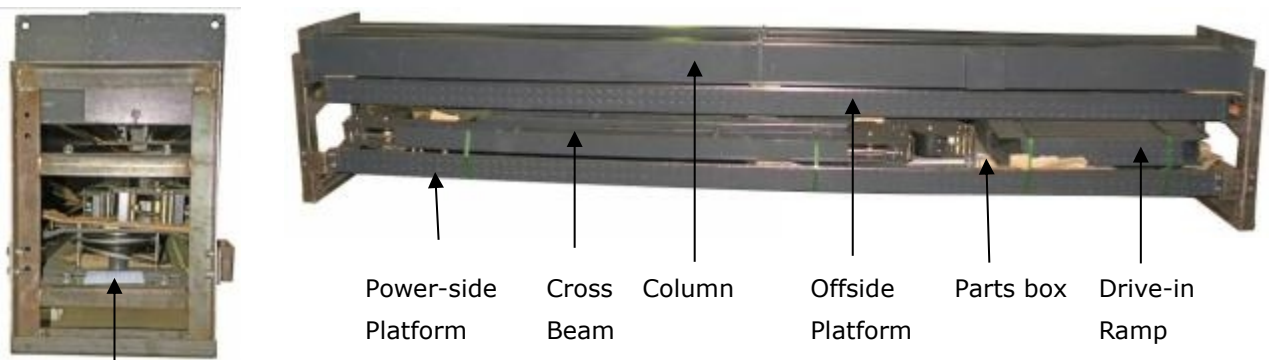

Shipment
Parts List

Fig. 6

3. Take off the drive-thru ramps and columns (See Fig.7).



Fig. 7

4. Loose the screws of the upper package stand, take off the offside platform, take out the parts inside the power-side platform, then remove the package stand.

5. Move aside the parts and check the parts according to the shipment parts list
(See Fig. 8).

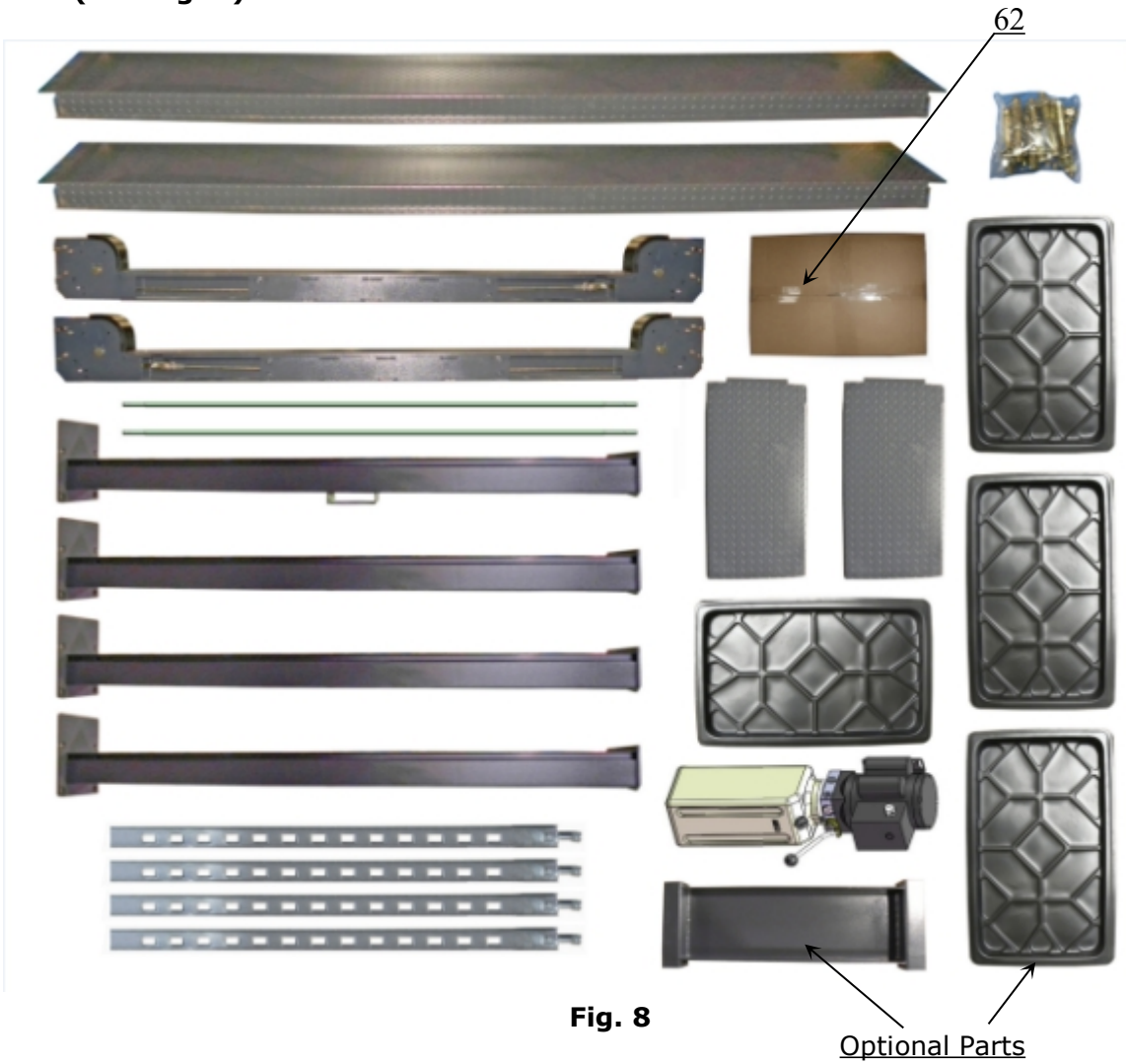

6. Open the carton of parts and check the parts according to the parts box list
(See Fig. 9).



7. Check the parts of the parts bag according to the parts bag list (See Fig. 10).



Fig. 10

B. Use a carpenter’s chalk line to establish installation layout as per Table 1
 Make sure the size is right and base is flat (see Fig. 11).

Note: Reserve space front and behind the installation site.

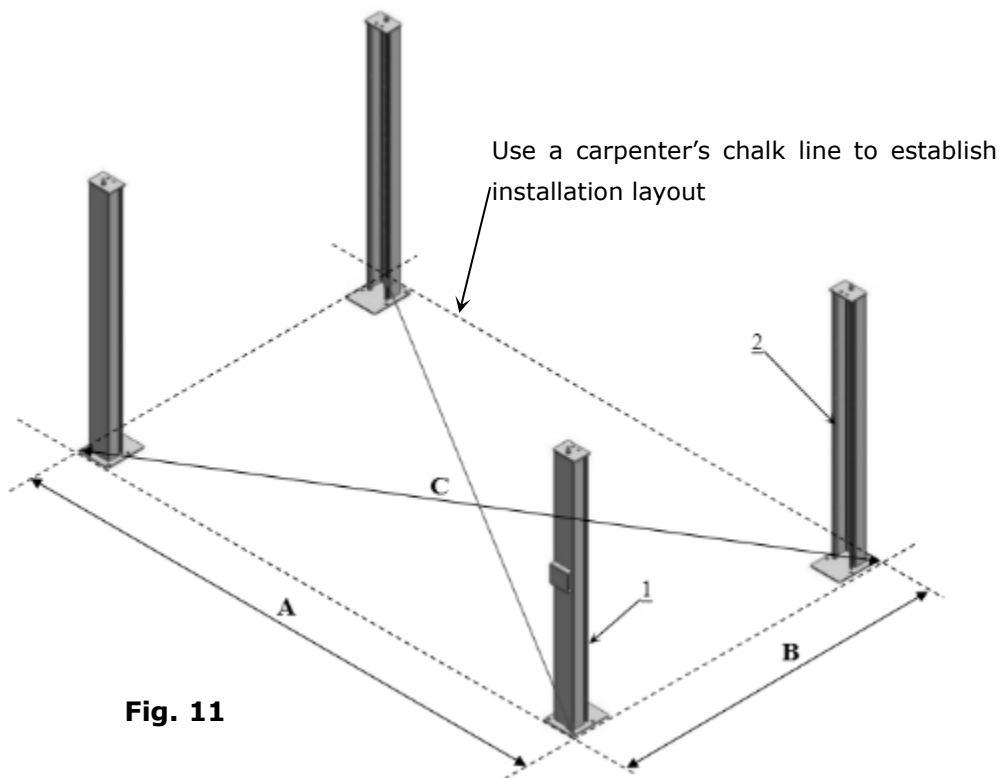
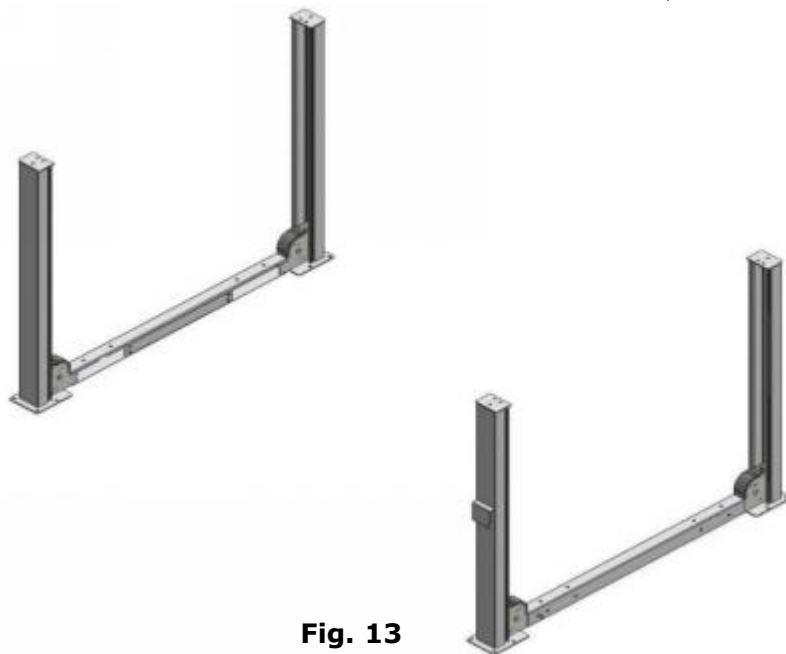
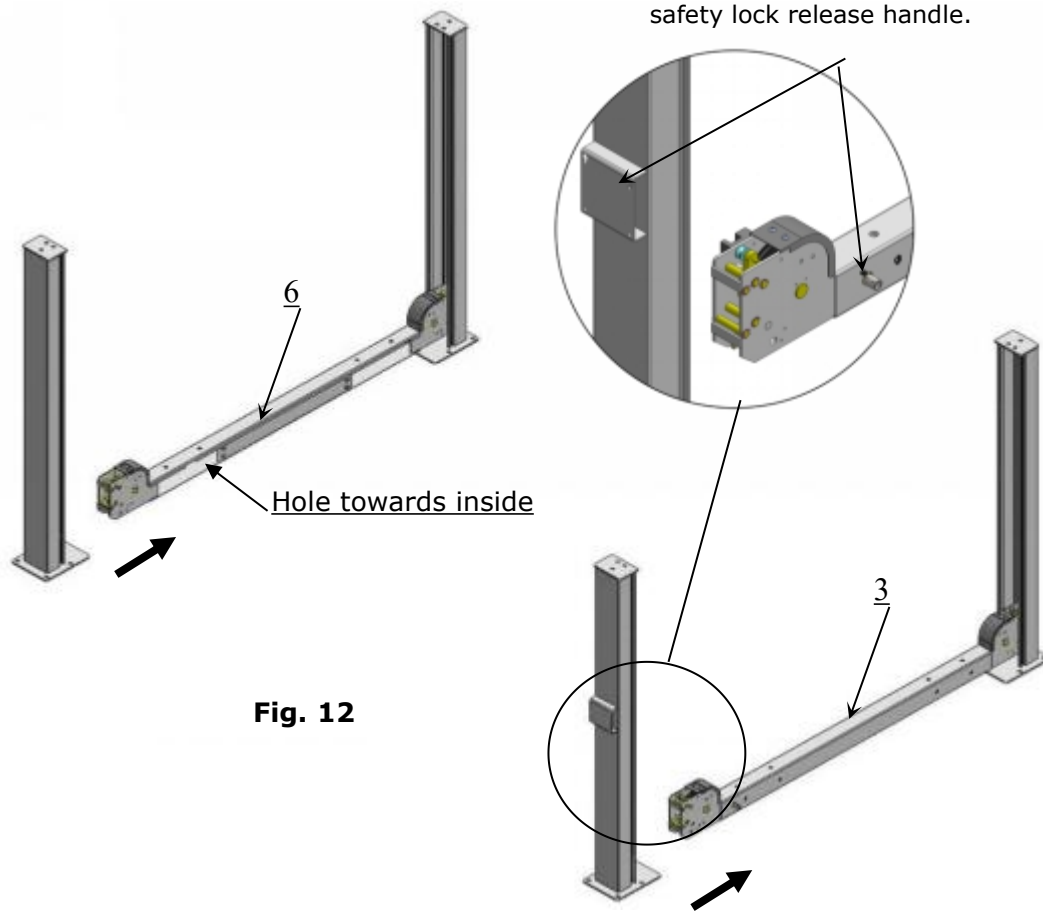

Fig. 11

MODEL	A	B	C
408-P	4400mm (173 1/4")	2784mm (109 5/8")	5207mm (205")

C. Install cross beams (See Fig.12, Fig.13).

The power-side column need to be installed according to the installed position of the safety lock release handle.



D. Install the Safety Ladders.

1. Take off the pulley safety cover and unscrew a nut of the safety ladders, and then adjust the four lower nuts to be at the same position. Then install the safety ladder

(See Fig. 14).

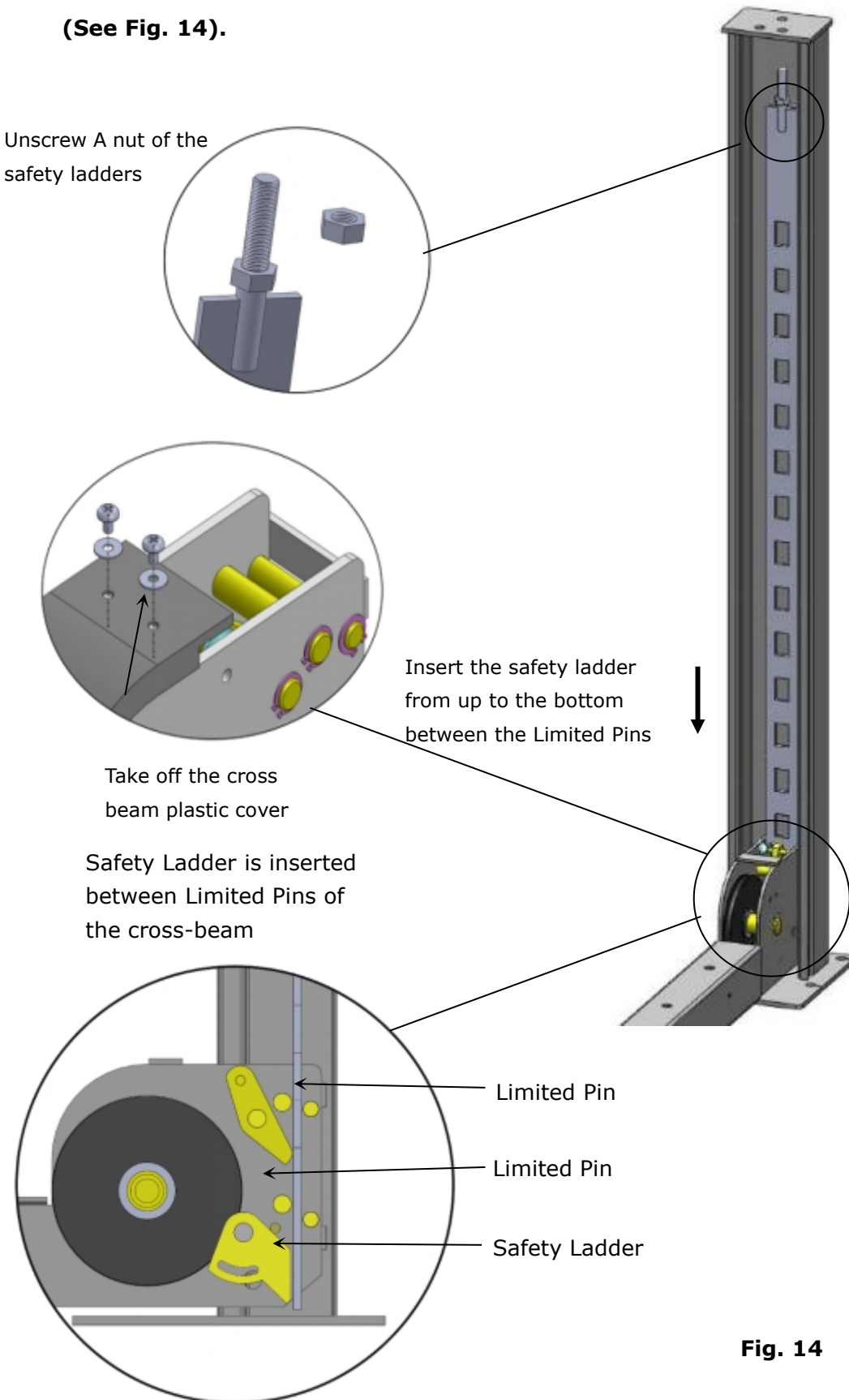
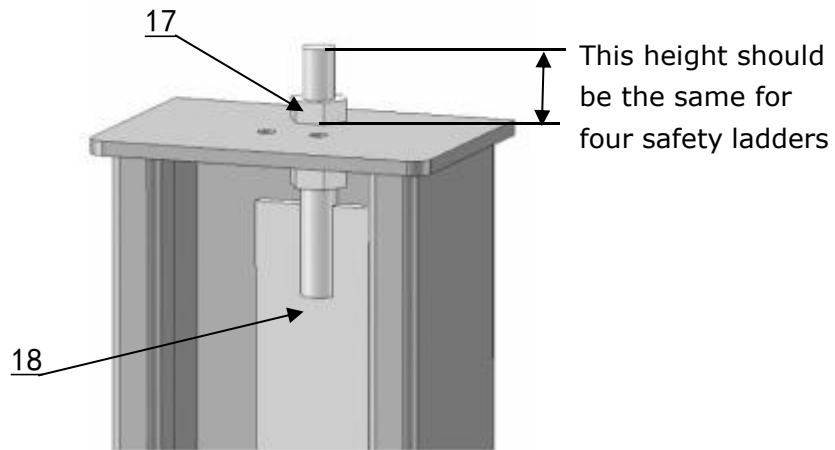

Fig. 14

2. Install Safety Ladders (See Fig. 15).



Safety ladder pass through the hole of the top plate, then tighten the two nuts

Fig. 15

E. Put the cross beams at the same height and lock on the safety ladder (See Fig. 15).

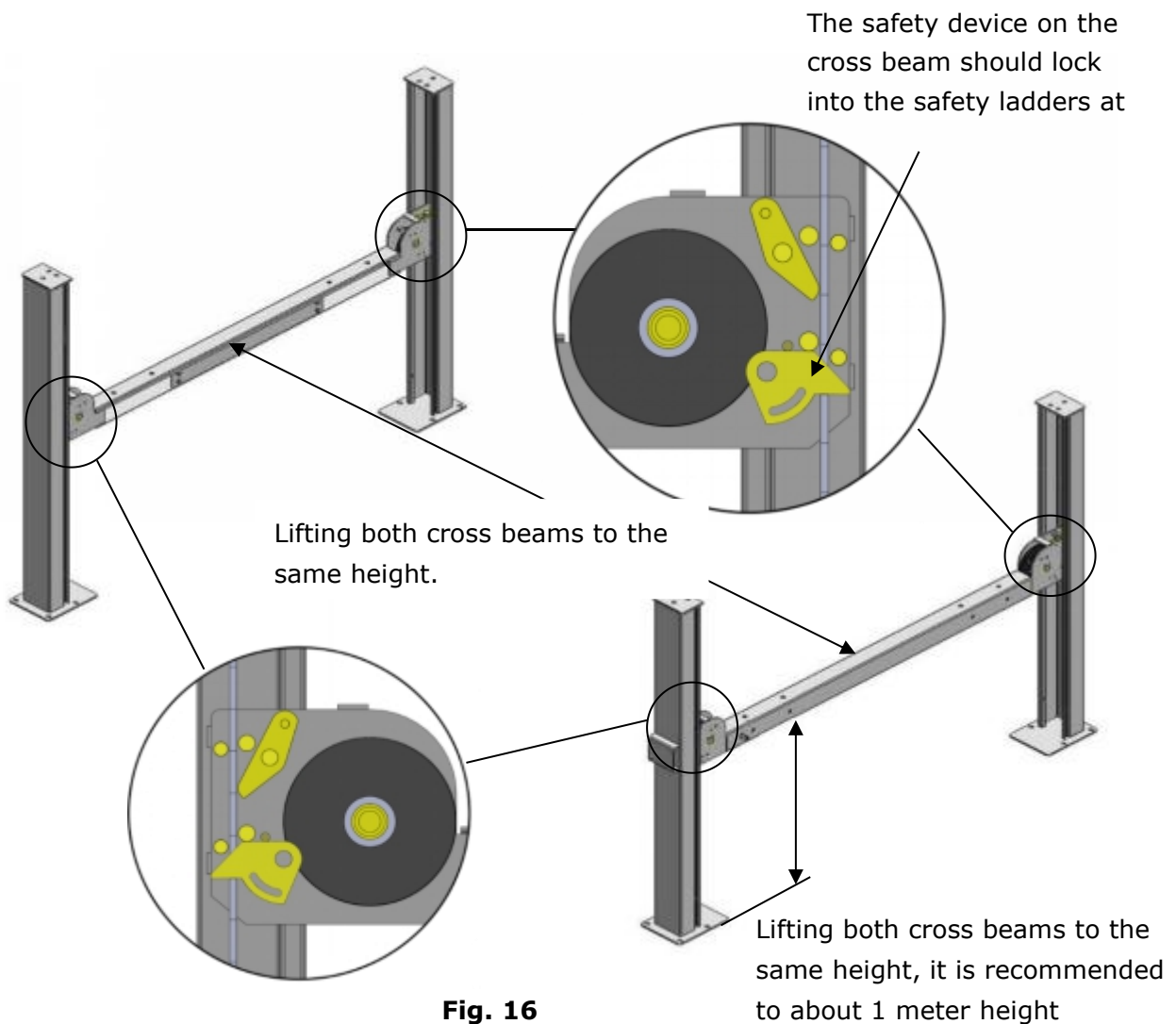
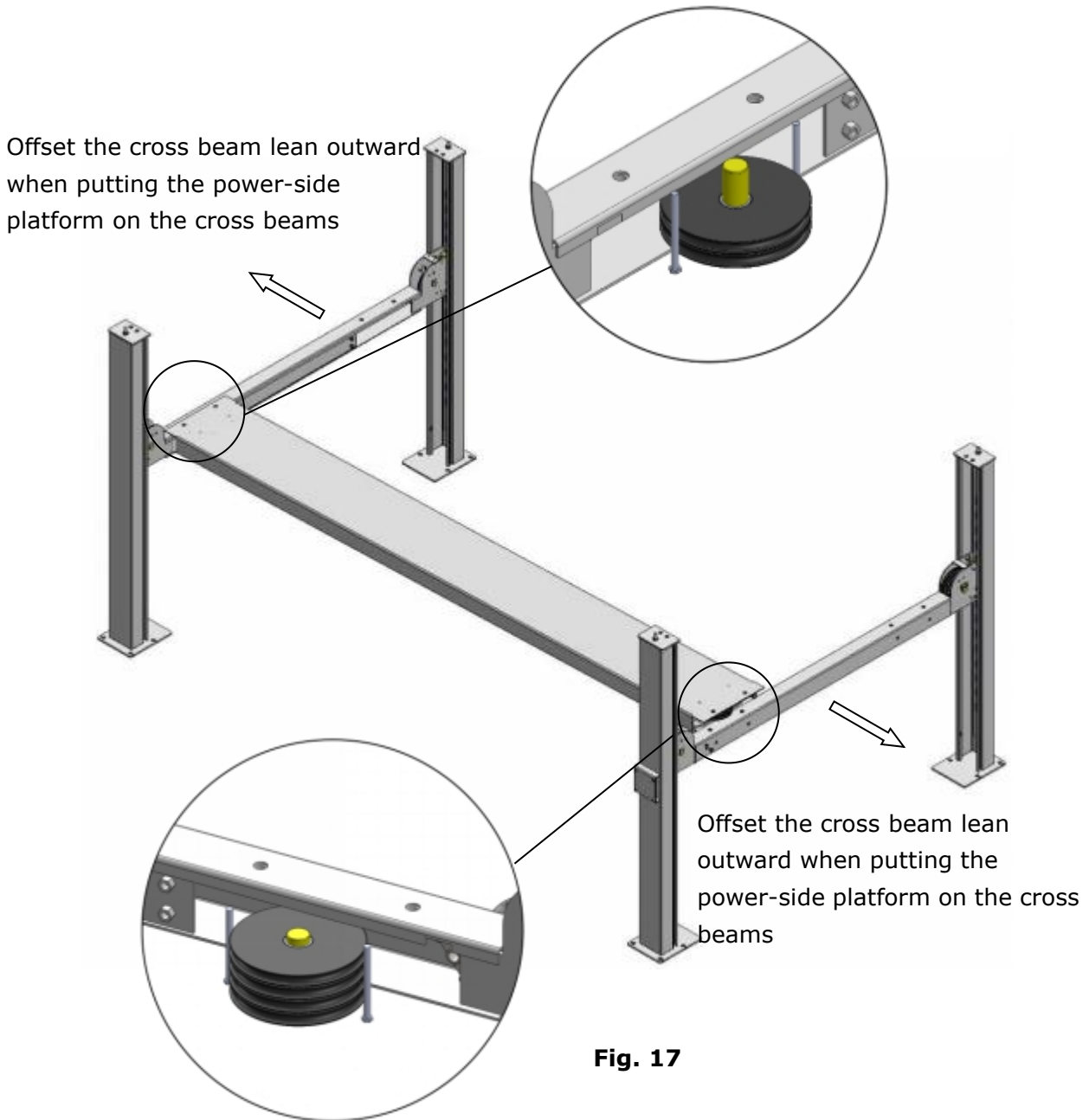

Fig. 16

F. Install power side platform.

1. Install the power side platform on the cross beams by a fork lift or manual, offset the cross beams to the outside till the pulleys of both platforms can rest into the cross beams' slots (**See Fig.17**), Install the power side platform and screw up the bolts.



2. **Install tire stop plate with bolts and washer on the platform:** Tighten the platform on cross beam **B** with bolts, tighten the tire stop plate on cross beam **A** with bolts

Note: The bolts for the side with tire stop plate is longer, pay attention when choosing the bolts (**See Fig.18**)

Instruction: 1). This lift is designed in both side (cross beam **A** and cross beam **B**) car in direction, user can install the lift according to the location. Below is the installation for the side of cross beam **B** car in direction. If choosing the side of cross beam **A** car in direction, then install the tire stop plate to the other side.

2). Power-side column can be installed at any position on customers' requirement, but the power unit must be installed near the side with the safety lock release handle.

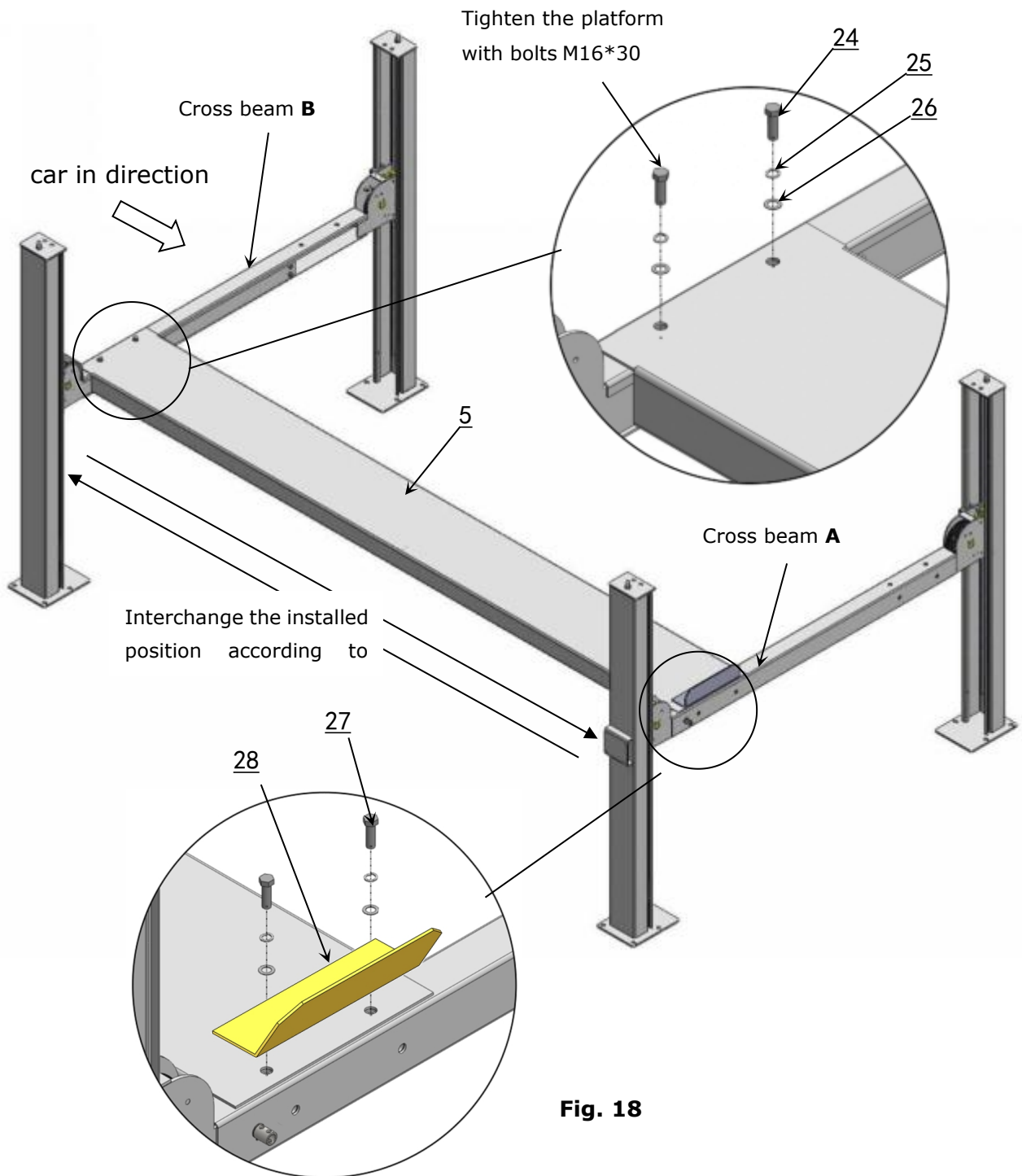
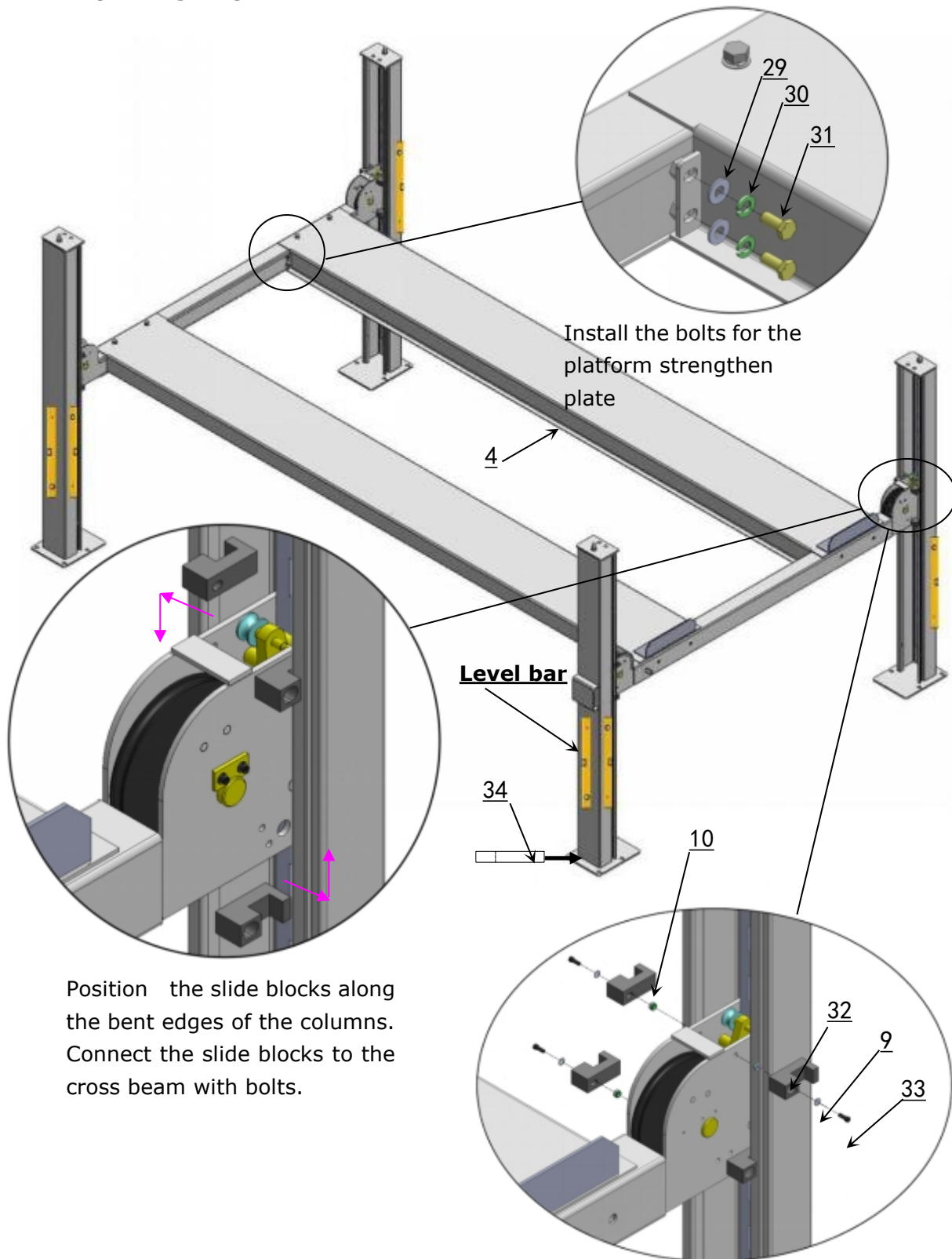

Fig. 18

G. Install offside platform and plastic block, then install the bolts for the platform strengthen plate, check the plumbness of columns with level and adjusting with the shims (**See Fig. 19**).



Position the slide blocks along the bent edges of the columns. Connect the slide blocks to the cross beam with bolts.

Note: DO NOT completely tighten the limit slide blocks. Loosen 1/4 lap after tightening.

Fig. 19

H. Illustration for cable installation

1. Pass through the cables from the platform to the columns according to the number of the cables (See Fig. 20).

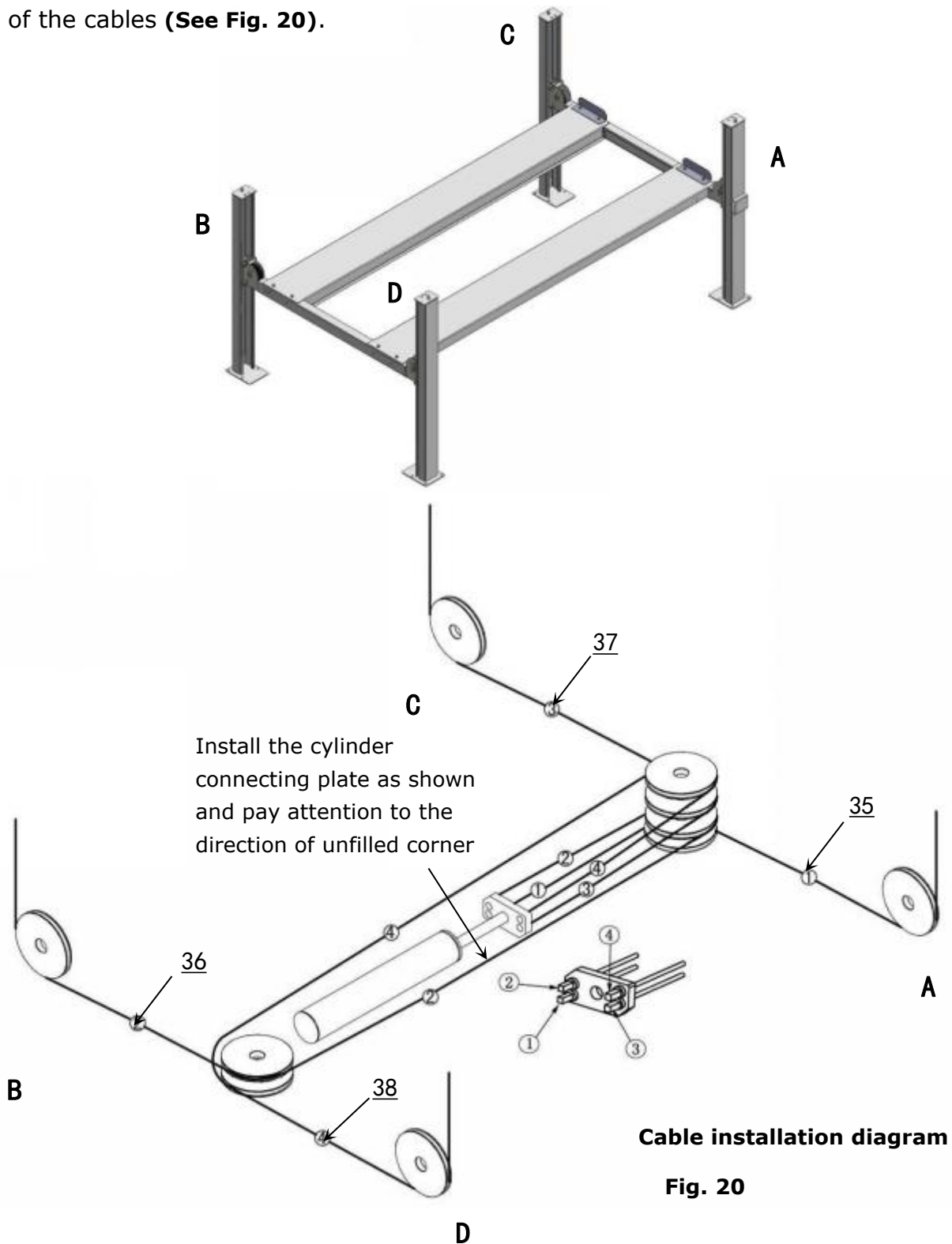

NO.	①	②	③	④
Cable				
Length (inc. connecting fitting)	2940mm (115 3/4")	8535mm (336")	4350mm (171 1/4")	7120mm (280 1/4")

2. The cable goes through the cross beam to top plate of columns and be screwed with cable nuts (**See Fig. 21**).

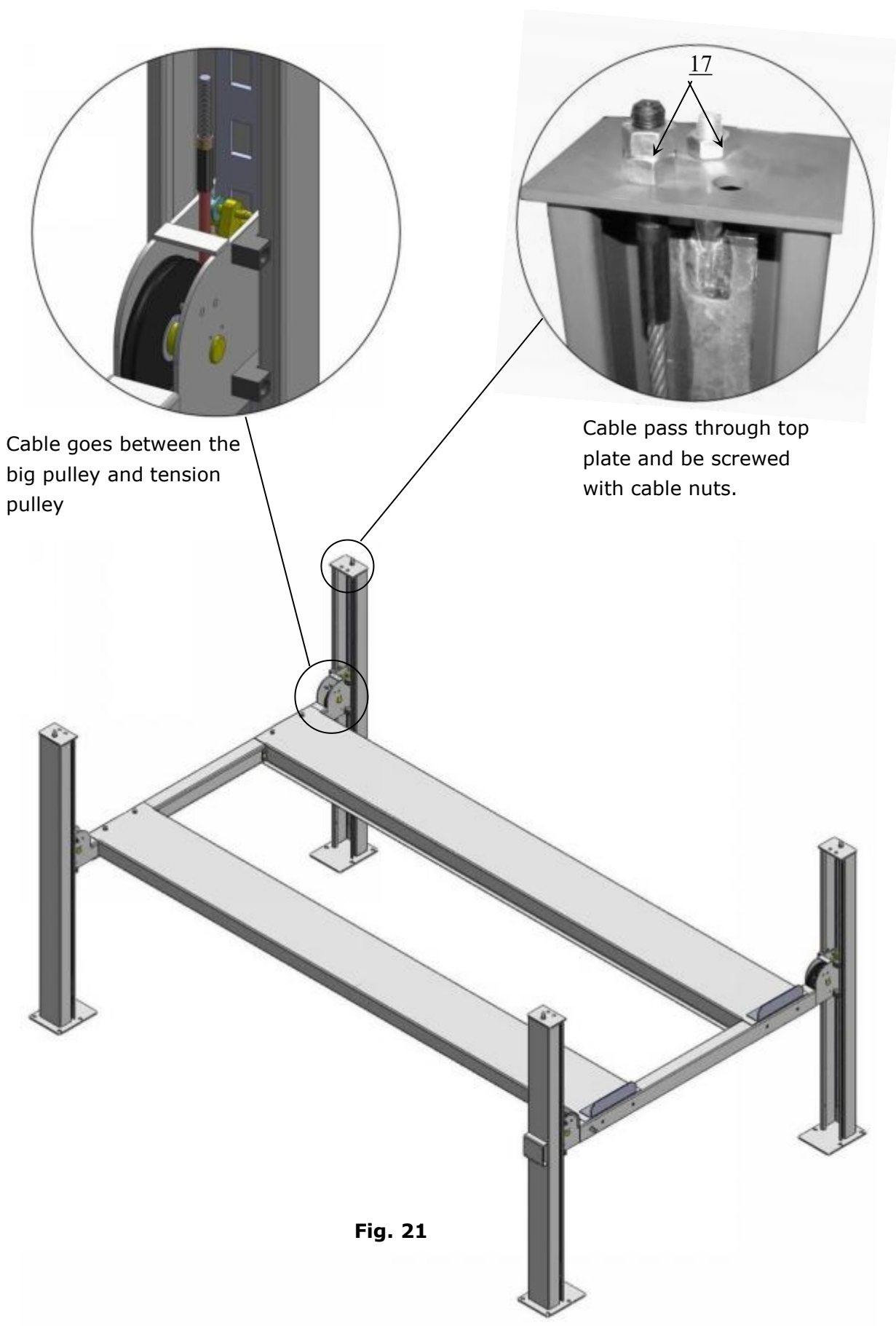

Fig. 21

3. Illustration for platform cables (See Fig. 22).

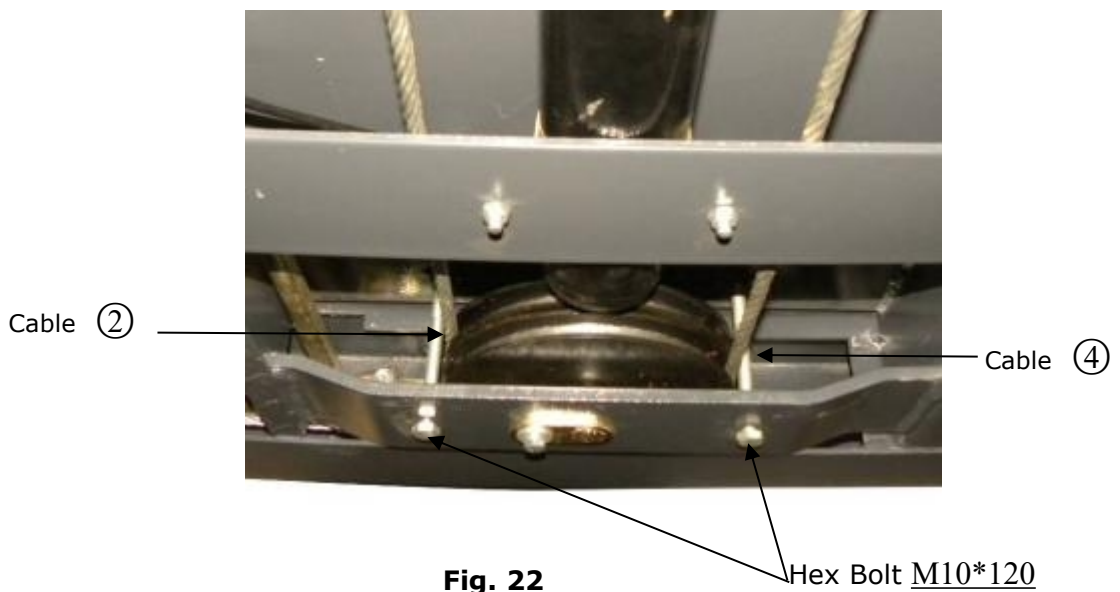
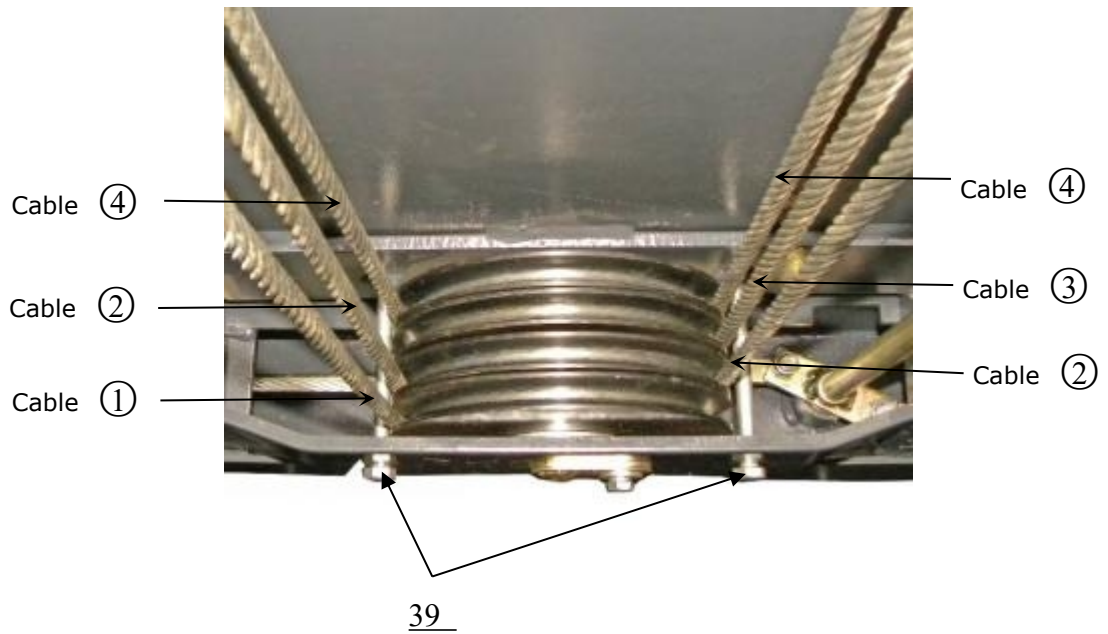
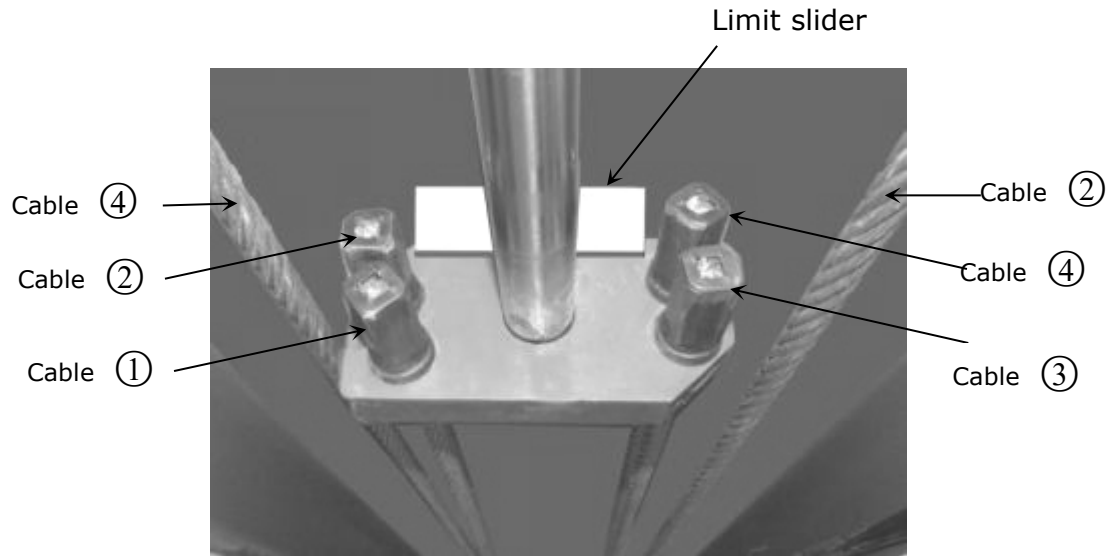

Fig. 22

I. Install release handle assy. See Fig.23

Noted: Power unit must be installed near the safety release handle.

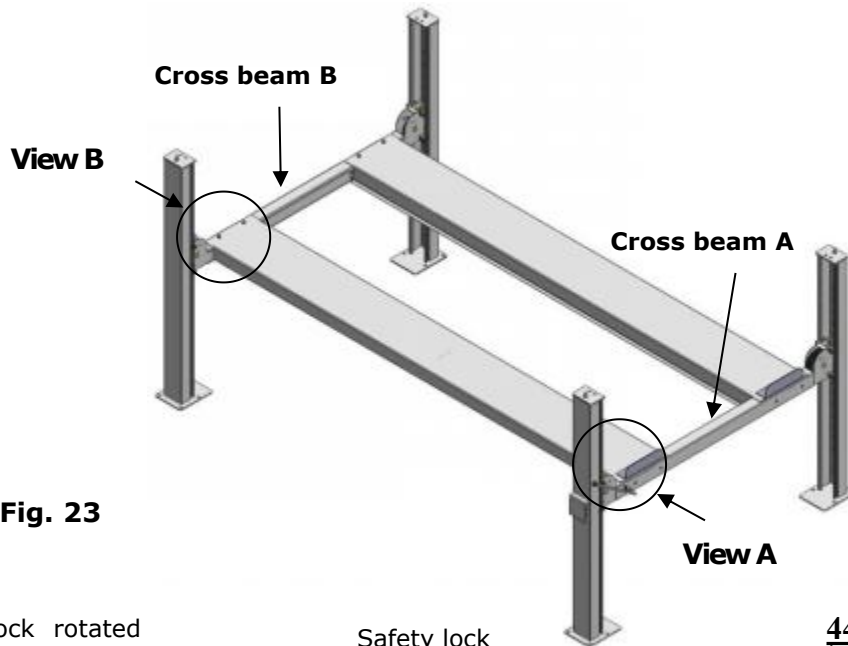
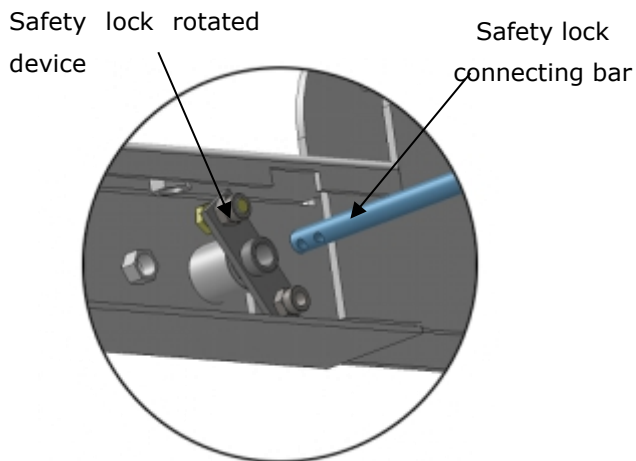
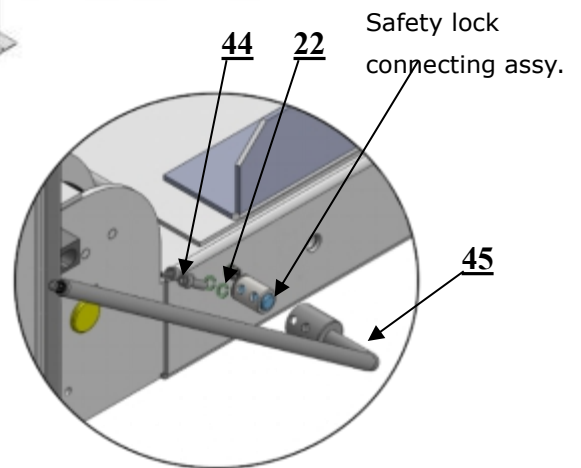

Fig. 23



Pass through the connecting bar from the safety lock rotated device of cross beam **A/B**



According to the above diagram, fix lock release handle and the safety lock connecting with M8*35 bolts and washers on cross beam **A**.

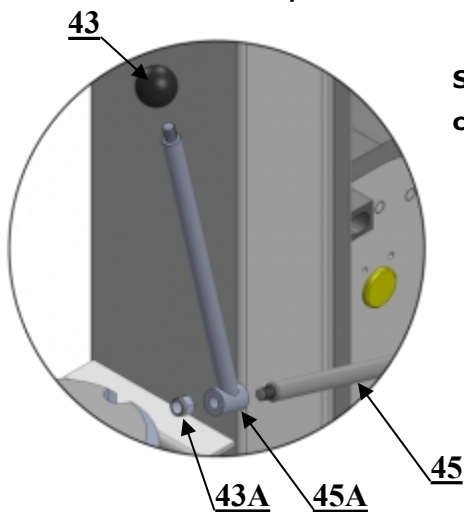

Install extend lock release handle and plastic ball

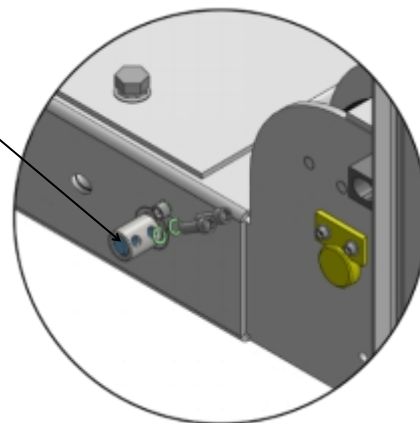

View B

According to the above diagram, fix safety lock connecting bar and safety lock connecting by M8*35 bolts and washers on cross beam **B**.

J. Install power unit and connecting tube (See Fig. 24).

Noted: Power unit must be installed near the safety release handle.

1. Install Power unit on the cross beam A

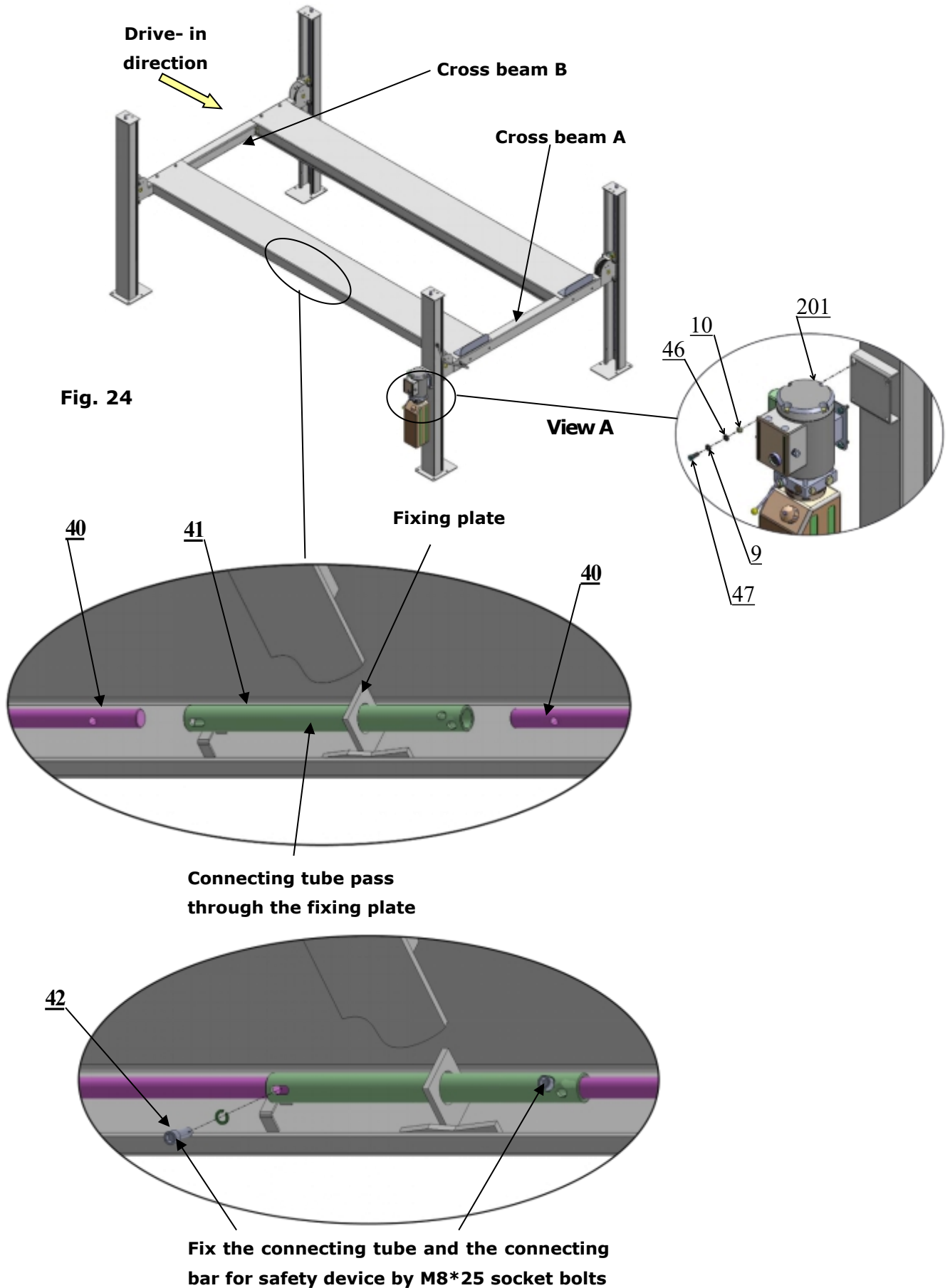

2. Install Power unit on the cross beam **B** (See Fig. 25).

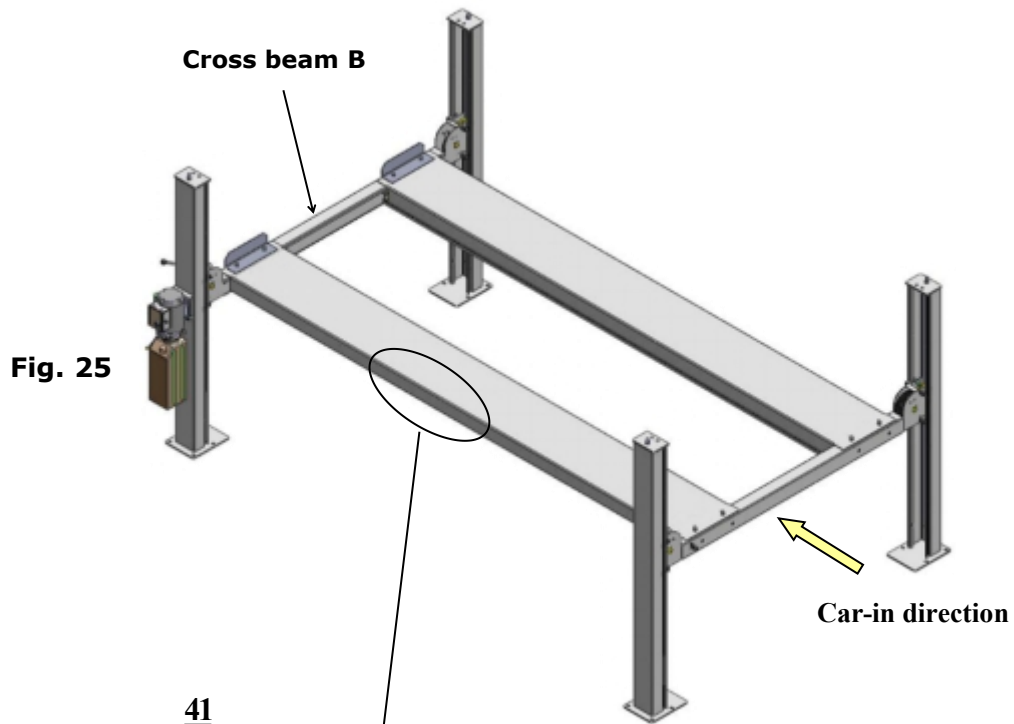
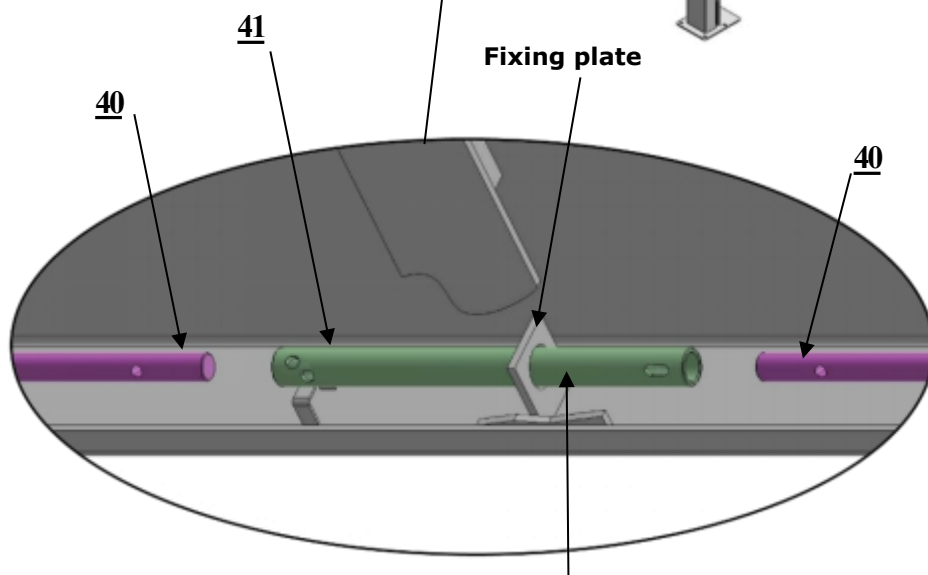
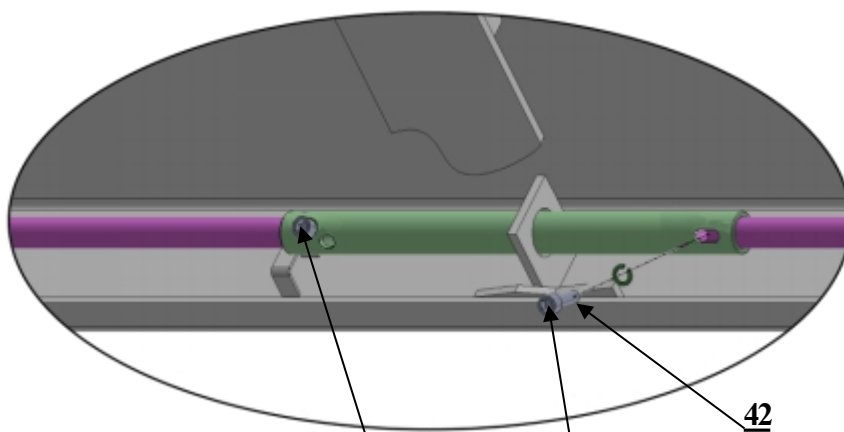

Fig. 25



Connecting tube pass through the fixing plate



Fix the connecting tube and the connecting bar for safety device by M8*25 socket bolts

K. Install Hydraulic System

1. For power unit attached to the column of cross beam **A** (See Fig. 26)

Note: Oil hoses connected to oil cylinder must be passed above the cable to avoid the oil hose scratched by cable.

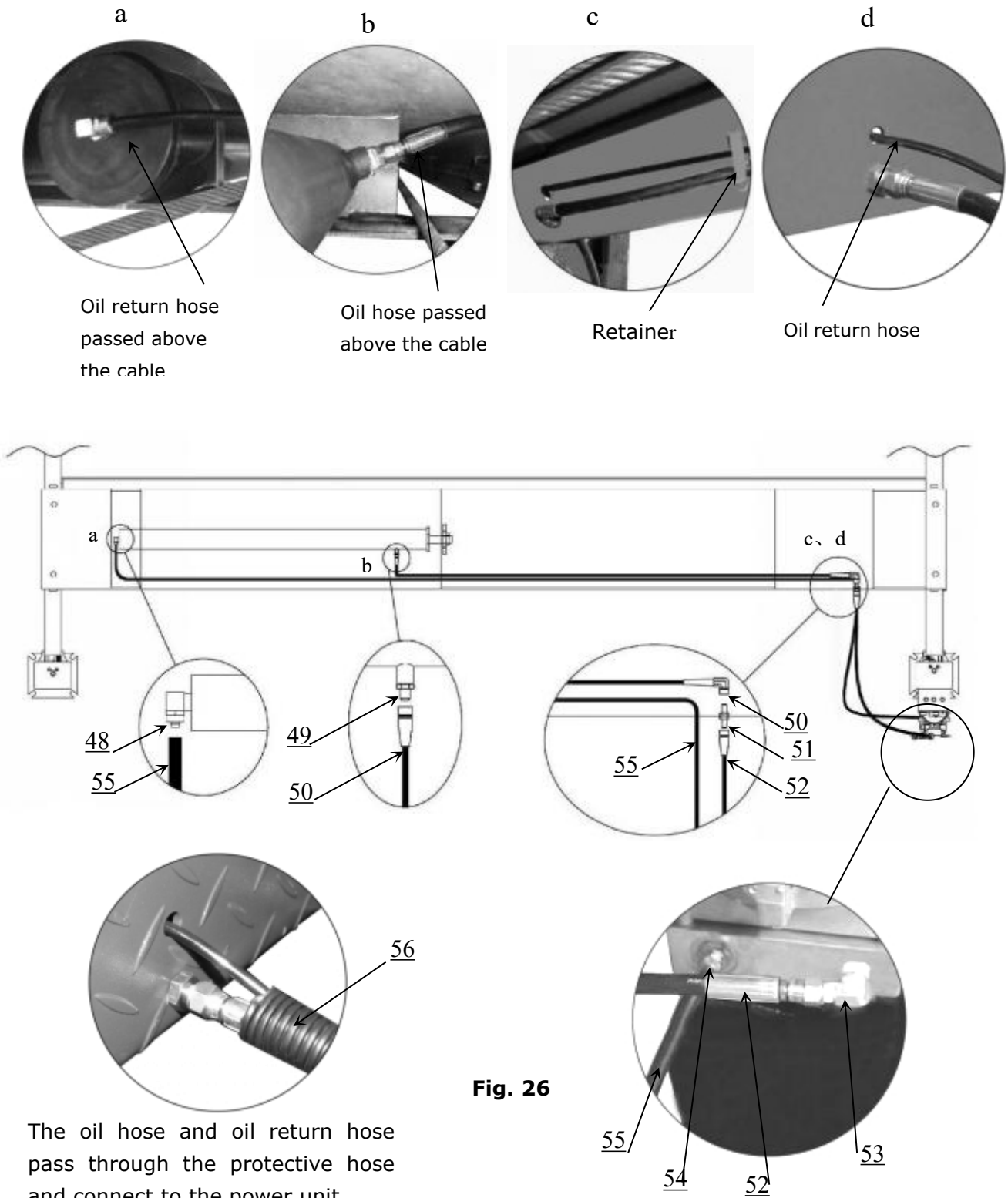

2. For power unit attached to the column of cross beam **B** (See Fig. 27).

Note: The oil return hose can be adjusted when installation

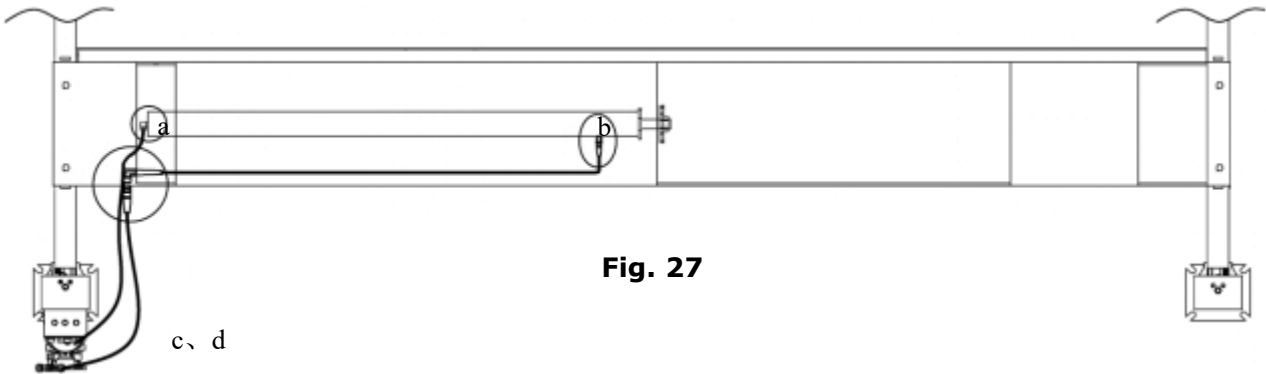

Fig. 27

L. Install Electrical System

Connect the power source on the data plate of Power Unit.

Note: For the safety of operators, the power wiring must contact the floor well.

Single phase motor (See Fig. 28).

1. Connecting the two power supply lines (active wire **L** and neutral wire **N**) to terminals of AC contactor marked **L1, L2** respectively.
2. Connecting the two motor wires to terminals of AC contactor marked **T1, T2**.
3. Connecting **A2** to **L2** of AC contactor.
4. Connecting the two wire of the button switch to the terminals of AC contactor marked **A1, L1**.

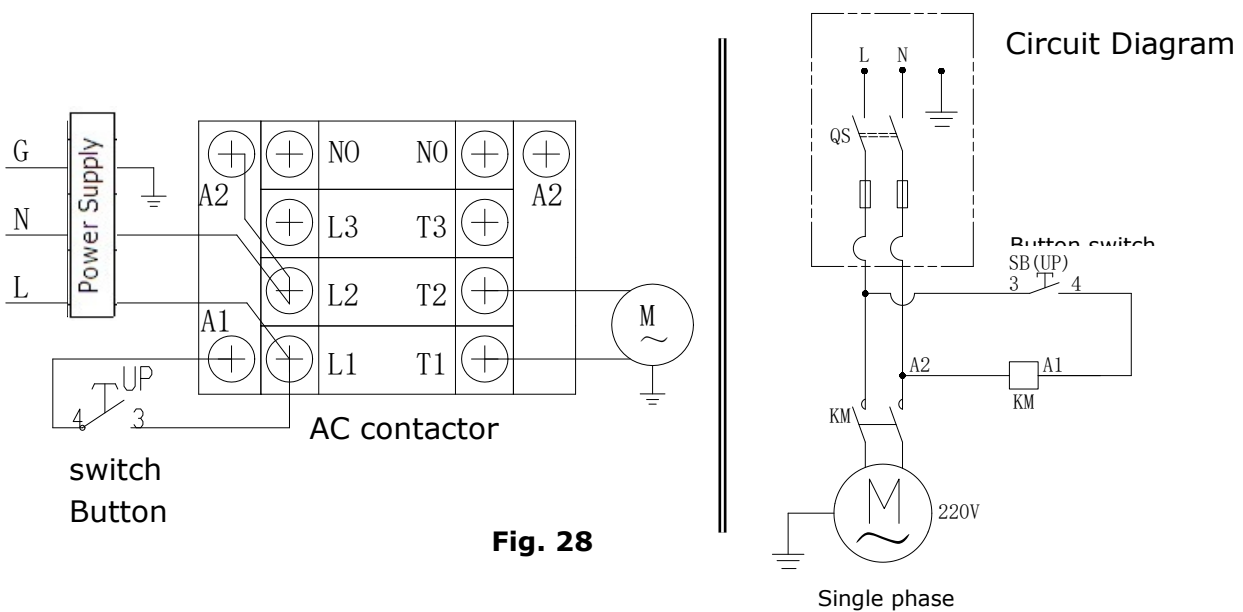

Fig. 28

M. Install spring and safety cover of cross beam (See Fig. 29).

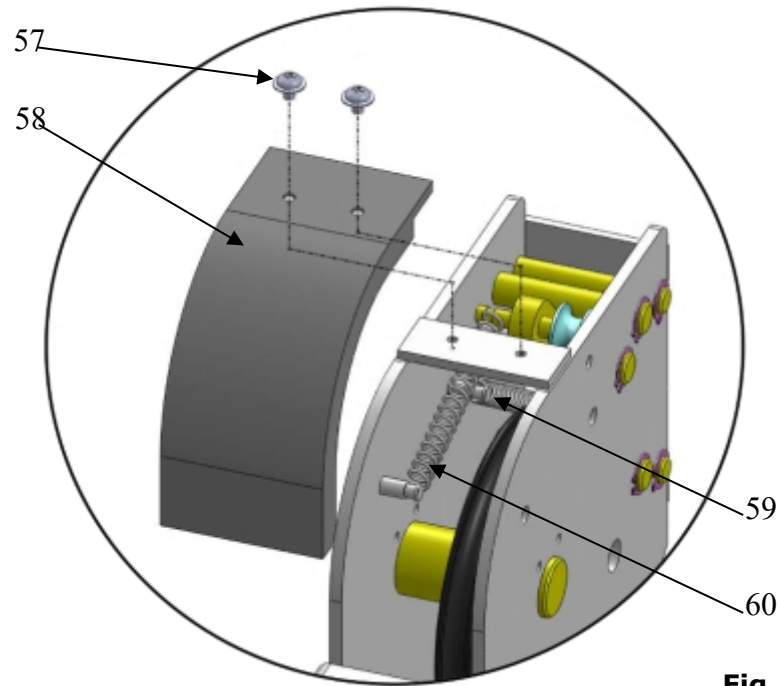

Fig. 29

N. Install drive-in ramp, optional jack tray and optional plastic oil pans (See Fig. 30).

According to the below diagram screw up the M16*30 bolts, then attach the drive-in ramp.

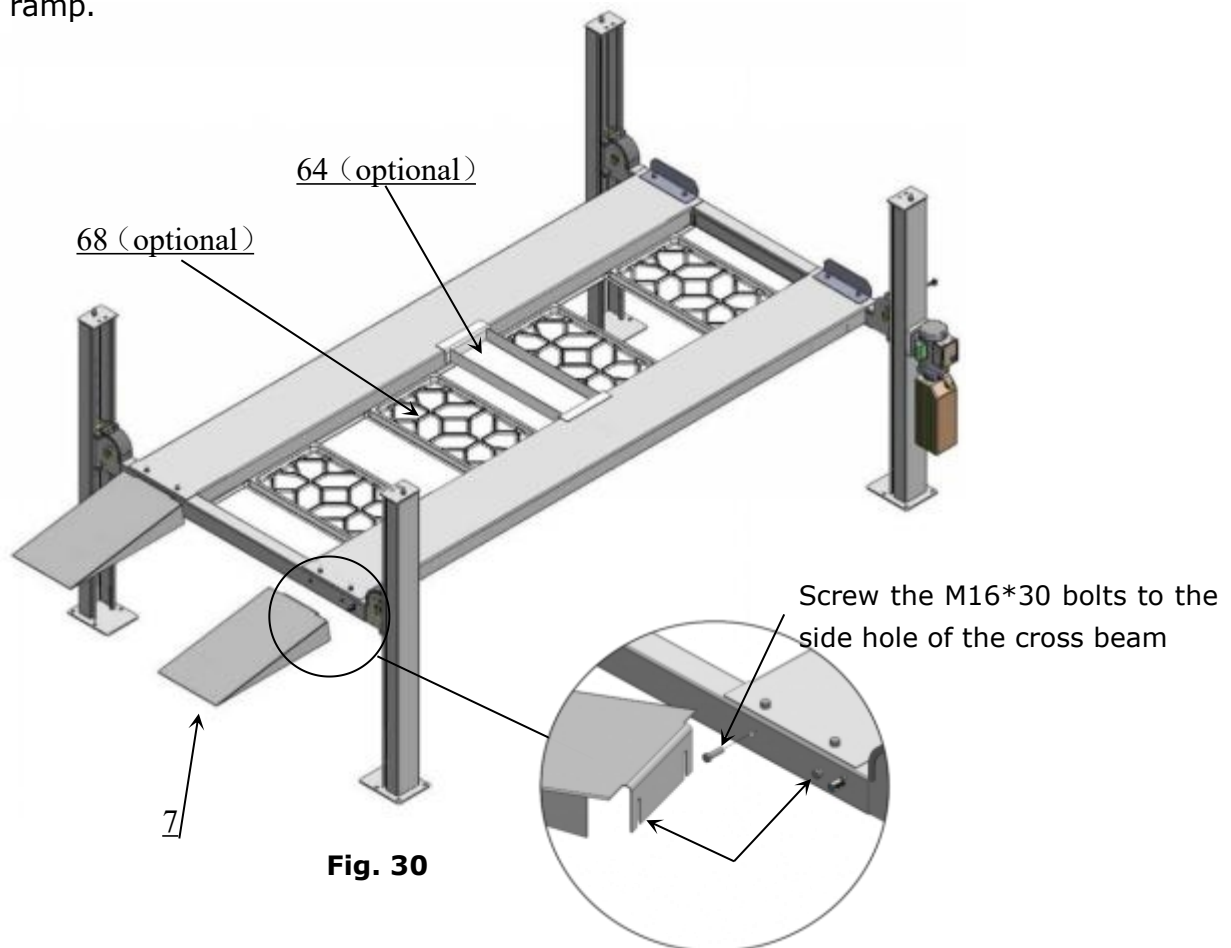

Fig. 30

O. Install Rear wheel stop plates (See Fig. 31)

After driving the vehicle on the lift, take off the drive-in ramp, install rear wheel stop plates to the drive-in ramp position.

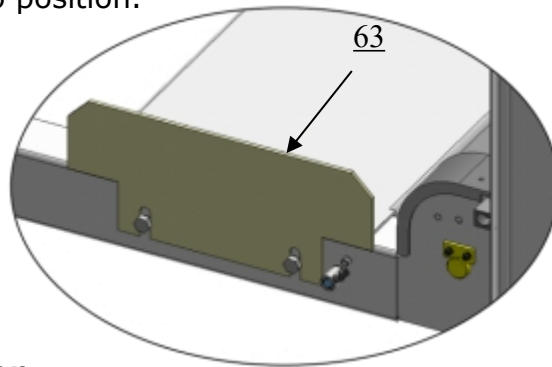

Fig. 31

For optional kits installation.

1. Install optional caster kits (See Fig. 32)

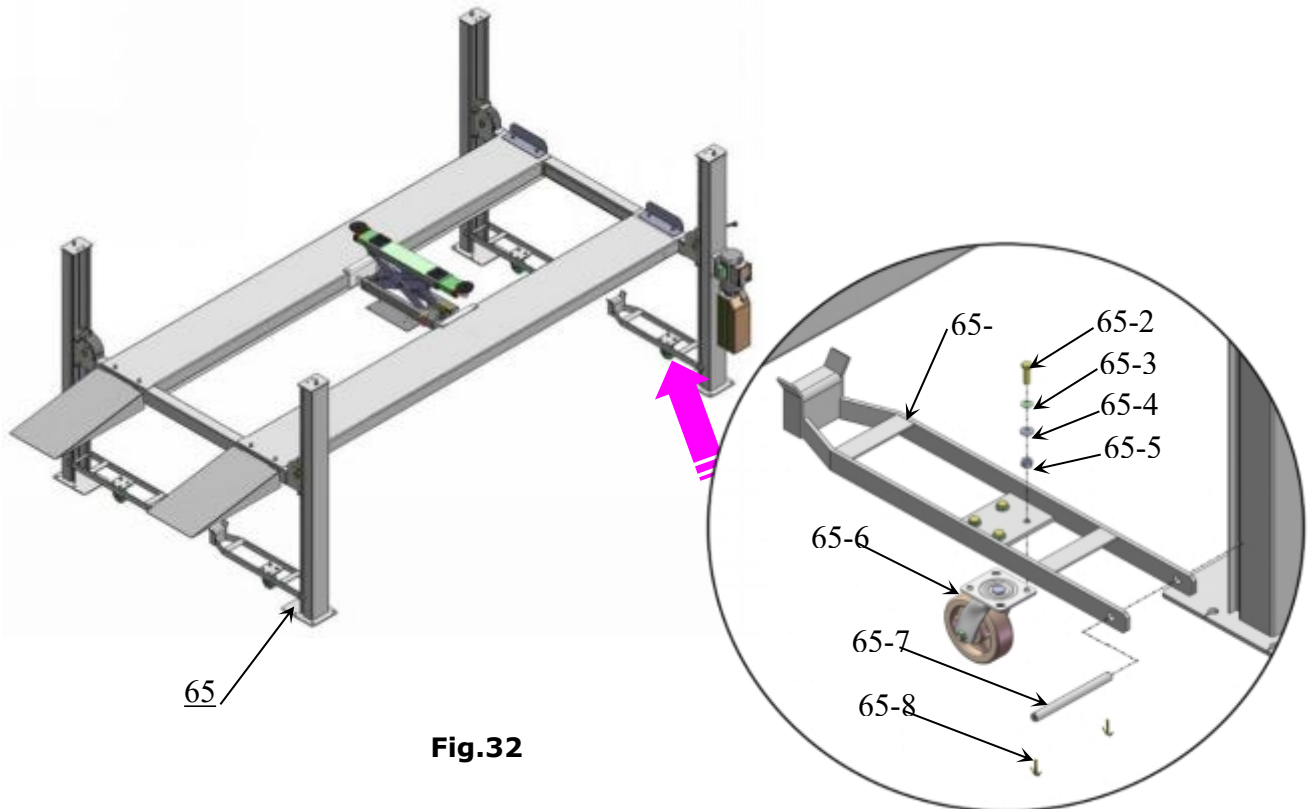
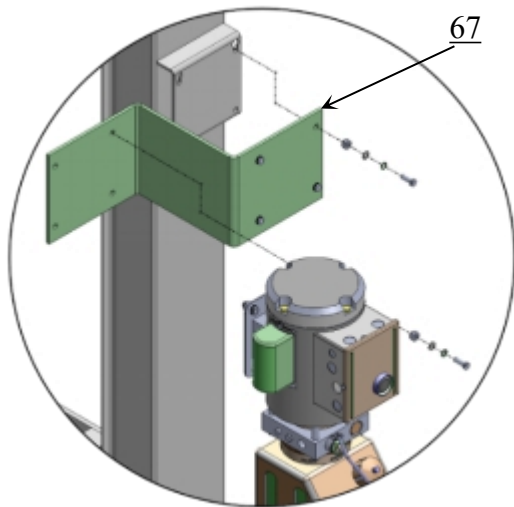

Fig.32

Item	Part#	Description	QTY.	Note
65-1	11410042A	Support bracket	4	
65-2	10209125	Hex bolt	16	
65-3	10209039	Lock washer	16	
65-4	10209022	Washer	16	
65-5	10209021	Hex nut	16	
65-6	10410035	Plastic wheel	4	
65-7	11410034	Connecting pin	4	
65-8	10209012	Hair Pin	8	

2. Install optional motor fixing bracket (See Fig. 33, Fig.34).



Motor fixing bracket on cross beam **A**
Fig. 33

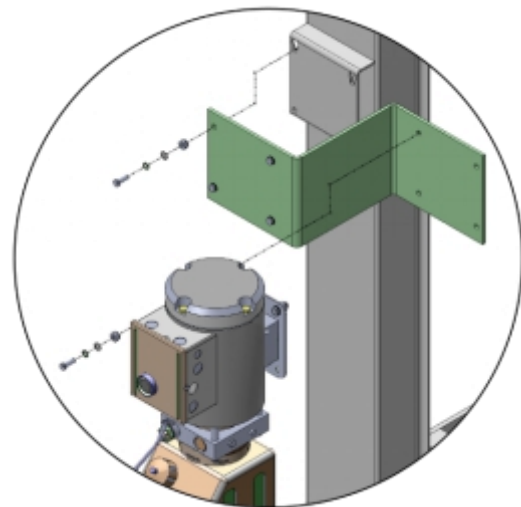

Motor fixing bracket on cross beam **B**
Fig. 34

P. Fix the anchor bolts

1. Prepare the anchor bolts (See Fig. 35).

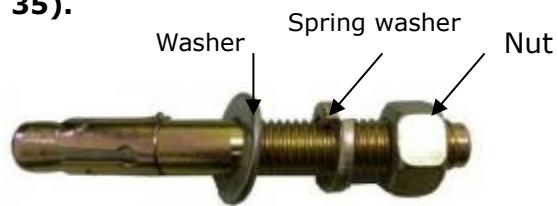

Fig. 35

2. Using the prescribed rotary hammer drill, and drill all the anchor holes and install the anchor bolts. Do not tighten the anchor bolts (See Fig. 36).

Note: The tightening torque for the anchor bolt is 150N.m ,Anchor bolts driven into the ground at least 90mm

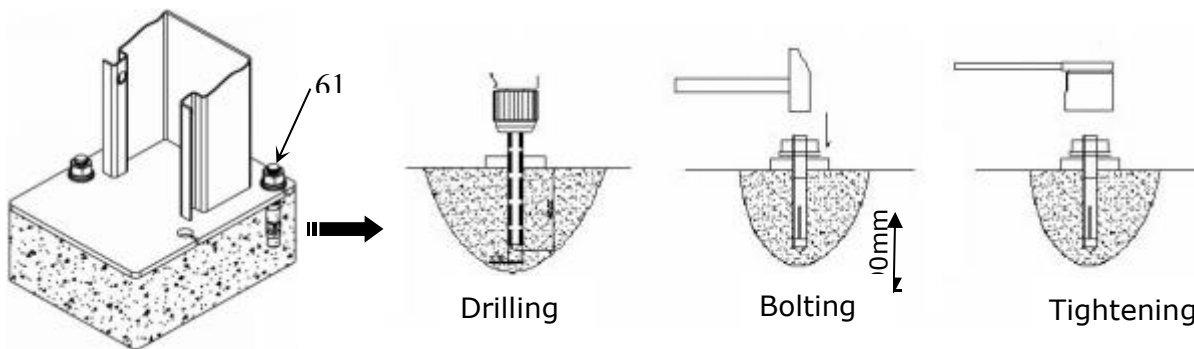

Fig. 36

IV. EXPLODED VIEW

Model 408-P

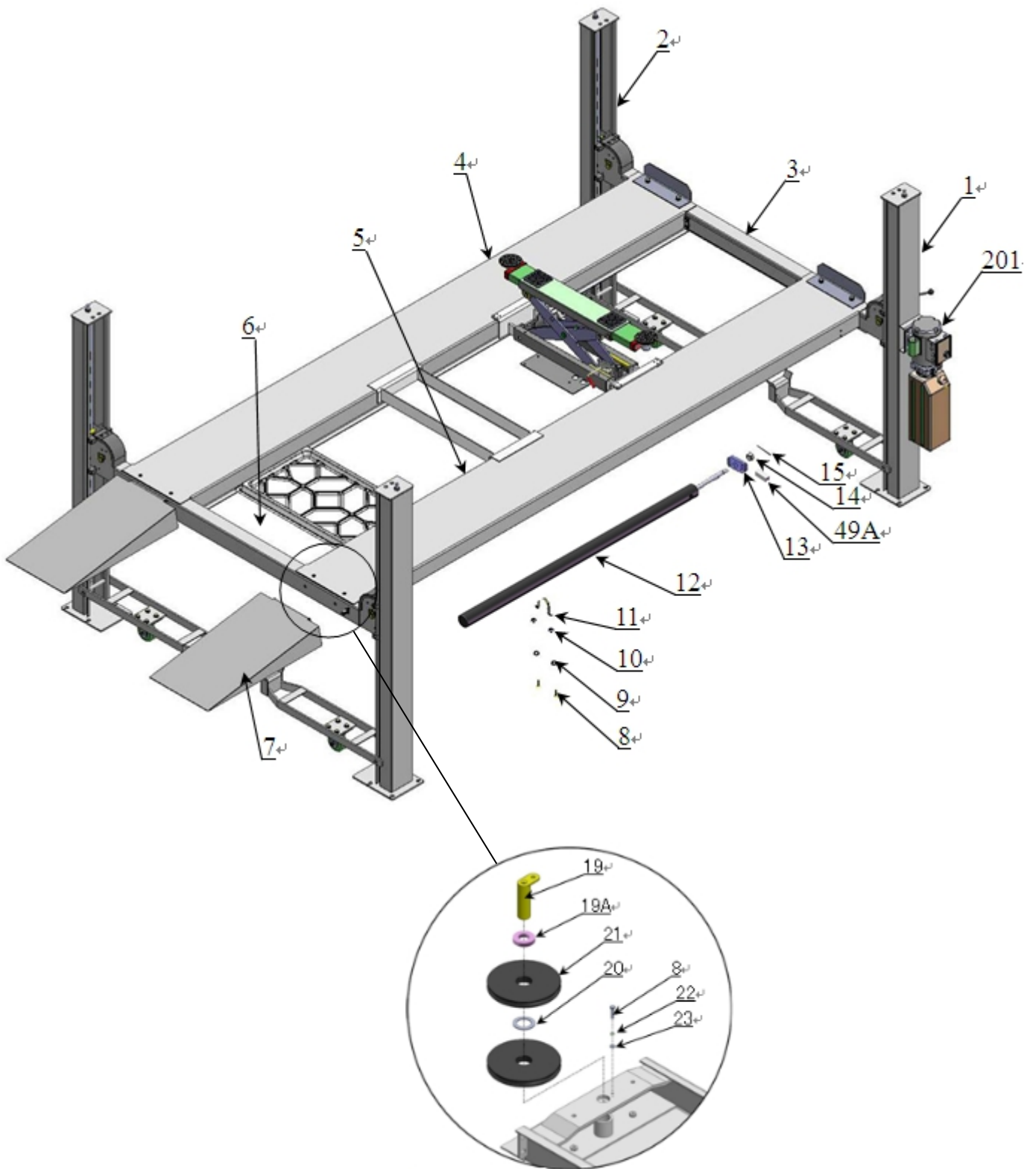

Fig. 37

PARTS LIST FOR MODEL 408-P

Item	Part#	Description	QTY.	Note
1	11410001	Power-side Column	1	
2	11410002	Offside Column	3	
3	11410003	Cross Beam A	1	
4	11410004	Offside Platform	1	
5	11410005	Power-side Platform	1	
6	11410006	Cross Beam B	1	
7	11410007	Drive-in ramp	2	
8	10209043	Hex Bolt	4	
9	10209033	Washer	28	
10	10209005	Self locking Nut	26	
11	11410008	Cylinder fixed ring	1	
12	10410009	Cylinder	1	
13	11410642	Cylinder connecting plate	1	
14	10410012	Hex Nut	1	
15	10201005	Split Pin	1	
201	81513006	Manual Power Unit	1	
17	10420175A	Hex nut	16	
18	11410022	Safety ladder	4	
19	10420022A	Pulley pin	2	
19A	11410106	Washer	1	
20	10420023A	Washer	13	
21	11420024B	Pulley	10	
22	10209034	Lock washer	10	
23	10420144	Washer	2	
24	10410013	Hex Bolt	8	
25	10420137	Lock washer	8	
26	10420029	Washer	8	
27	10410014	Hex Bolt	4	
28	11410116-1	Tire stop plate	2	
29	10206006	Washer	12	
30	10420026	Lock washer	8	
31	10410105	Hex Bolt	8	
32	10410016A	Plastic block	16	
33	10410017	Socket bolt	16	
34	10201090	Shim (1mm)	20	
	10620065	Shim (2mm)	20	
35	10410019	Cable ①	1	
36	10410020	Cable ②	1	
37	10410018	Cable ③	1	
38	10410021	Cable ④	1	
39	10600015	Socket Bolt	4	
40	11410023	Connecting bar for safety device	2	

Item	Part#	Description	QTY.	Note
41	11410024	Connecting tube	1	
42	10209032	Socket bolt	4	
43	10217005	Plastic ball	1	
43A	10209056	Self locking Nut	1	
44	10410025	Socket bolt	4	
45	11410026	Safety release handle	1	
45A	11410100	Extension lock release handle	1	
46	10209004	Rubber ring	4	
47	10209003	Hex Bolt	8	
48	10420166	90° Fitting	1	
49	10420119	Straight Fitting for cylinder	1	
49A	10410135	Limit block	1	
50	10410027	Oil hose	1	
51	10420120	Extend straight fitting with nut	1	
52	10207026	Oil hose	1	
53	10209060	90° Fitting for power unit	1	
54	10420095	Straight fitting	1	
55	10410028	Oil return hose	1	
56	10410036	Protective hose	1	
57	10209145A	Cup head bolt with washer	8	
58	10410029	Plastic cover for cross beam	4	
59	10410146	Spring	4	
60	10420033	Spring	4	
61	10209059	Anchor bolt	16	
62	10410500A	Parts box	1	
63	11410094	Tire stop plate	2	
Optional kits				
64	11410040	Jack tray	1	
65	1040801	Caster kits	4	
66	96600002	Sliding jack	1	
67	1140802B	Motor fixing bracket	1	
68	10410039	Plastic oil tray	4	

4.1 CYLINDERS (10410009)

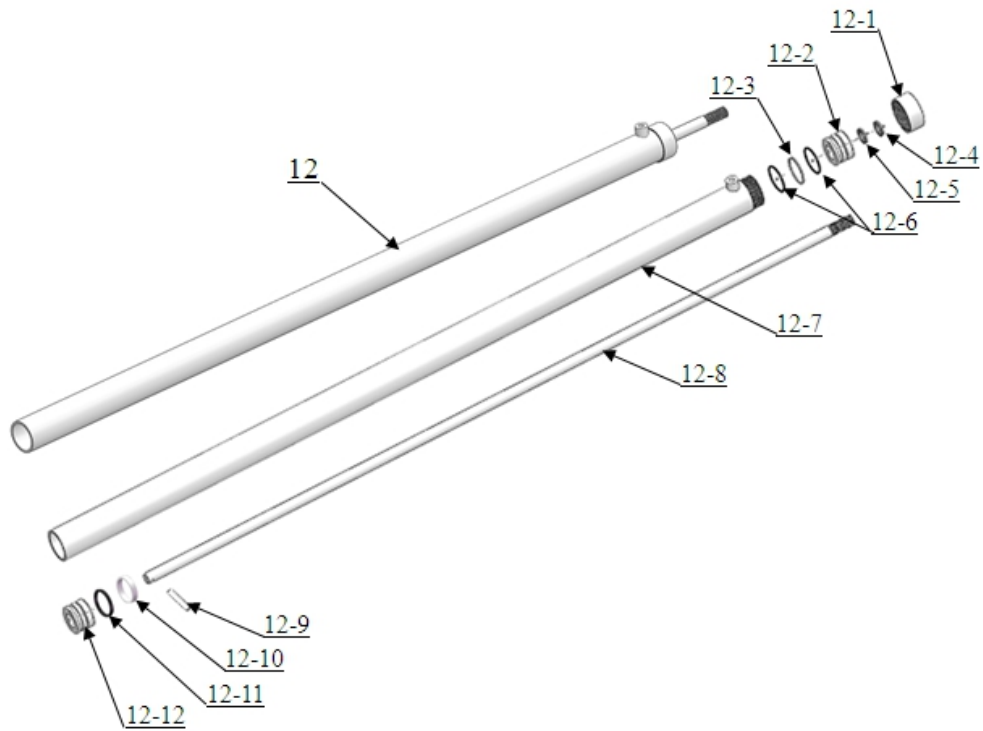

Fig.38

Parts For Cylinder

Item	Part#	Description	QTY.	Note
12-1	11410044	Head Cap	1	
12-2	11440620	Head Cap cover	1	
12-3	10410142	Support Ring	1	
12-4	10410080	Dust Ring	1	
12-5	10410104	Y- Ring	1	
12-6	10201031	O- Ring	2	
12-7	11410046	Bore Weldment	1	
12-8	11410047	Piston Rod	1	
12-9	11410049	Pin	1	
12-10	10520052	Support Ring	1	
12-11	10201030	Y- Ring	1	
12-12	11410048	Piston	1	

4.2 CROSS BEAM (10410003/10410006)

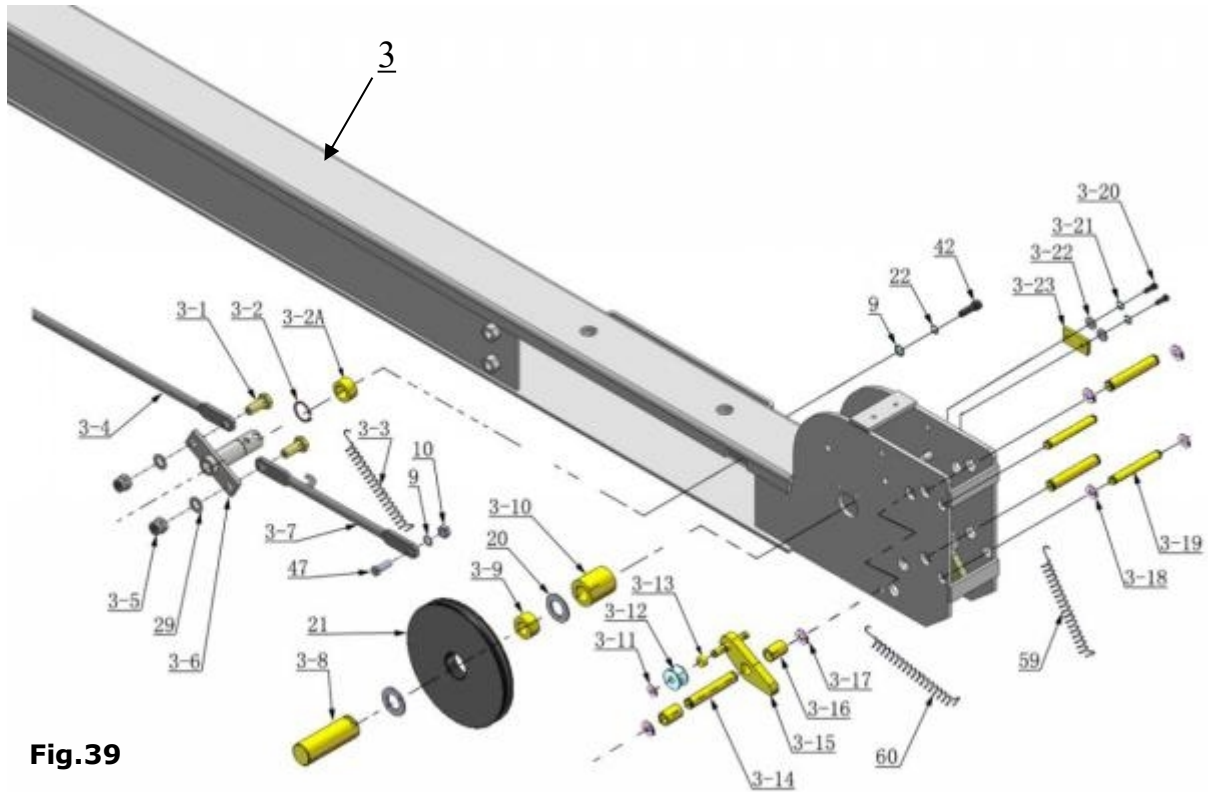

Fig.39

Item	Part#	Description	QTY.	Note
3-1	10206024	Hex Bolt	4	
3-2	10206032	Snap Ring	2	
3-2A	10217020	Bronze Bush	2	
3-3	10410099	Spring	2	
3-4	11410031	Connecting bar for safety lock	2	
3-5	10206023	Self locking Nut	4	
3-6	11410032	Safety lock rotated device assy.	2	
3-7	11410033	Connecting bar assy. for safety lock	2	
3-8	11420041A	Pulley Pin	4	
3-9	10420132A	Pulley Bush	10	
3-10	11420040A	Pulley pin sleeve	4	
3-11	10209010	Snap ring	4	
3-12	10420035	Tension pulley	4	
3-13	11420174	Spacer	4	
3-14	11420171	Pin	12	
3-15	11420175	Slack-cable safety lock (Left & Right)	2 each	
3-16	11420172	Pin Bush For Slack-cable safety lock	8	
3-17	10206019	Snap ring	24	
3-18	10420037	Snap ring	16	
3-19	11420038	Pin	8	
3-20	10420138	Socket Bolt	8	
3-21	10209149	Lock washer	8	
3-22	10420045	Washer	8	
3-23	11420044	Stop block	4	

4.3 Manual Power Unit (071104)

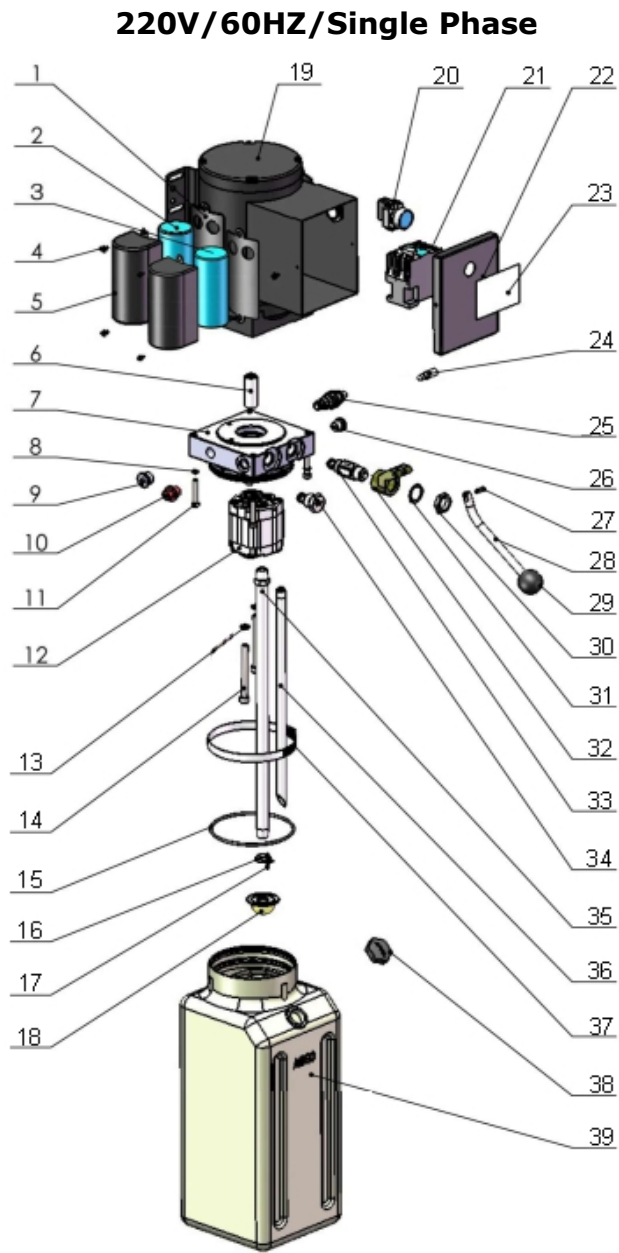

Fig. 40

Item	Part#	Description	QTY.	Note
1	81400180	Rubber Pad	2	
2	81400130	Start Capacitor	1	
3	81400088	Run Capacitor	1	
4	10420148	Cup Head bolt with washer	4	
5	81400066	Capacitor cover	2	
6	81400363	Motor Connecting Shaft	1	
7	090101	Manifold block	1	
8	10209149	Lock washer	4	
9	81400276	Iron Plug	1	
10	81400259	Rubber Plug	1	
11	85090142	Socket Bolt	4	
12	81400280	Gear Pump	1	
13	10209034	Lock Washer	2	
14	81400295	Socket Bolt	2	
15	81400365	O Ring	1	
16	10209152	Tie	1	
17	85090167	Magnet	1	
18	81400290	Filter	1	
19	81400413	Motor	1	
20	10420070	Button	1	
21	41030055	Ac Contactor	1	
22	81400287	Terminal Box Cover	1	
23	71111174	Sticker	1	
24	81400560	Throttle valve	1	
25	81400266	Relief Valve	1	
26	81400284	Iron Plug	1	
27	10720118	Pin	1	
28	81400451	Release Valve Handle	1	
29	10209020	Plastic Ball	1	
30	81400421	Release Valve Nut	1	
31	81400422	Self Lock washer	1	
32	81400449	Valve Seat	1	
33	81400567	Release Valve	1	
34	81400566	Check Valve	1	
35	81400288	Oil suction hose	1	
36	81400289	Oil return hose	1	
37	81400364	clamp	1	
38	81400263	Oil tank cover	1	
39	81400320	Oil tank	1	

Illustration of hydraulic valve for hydraulic power unit

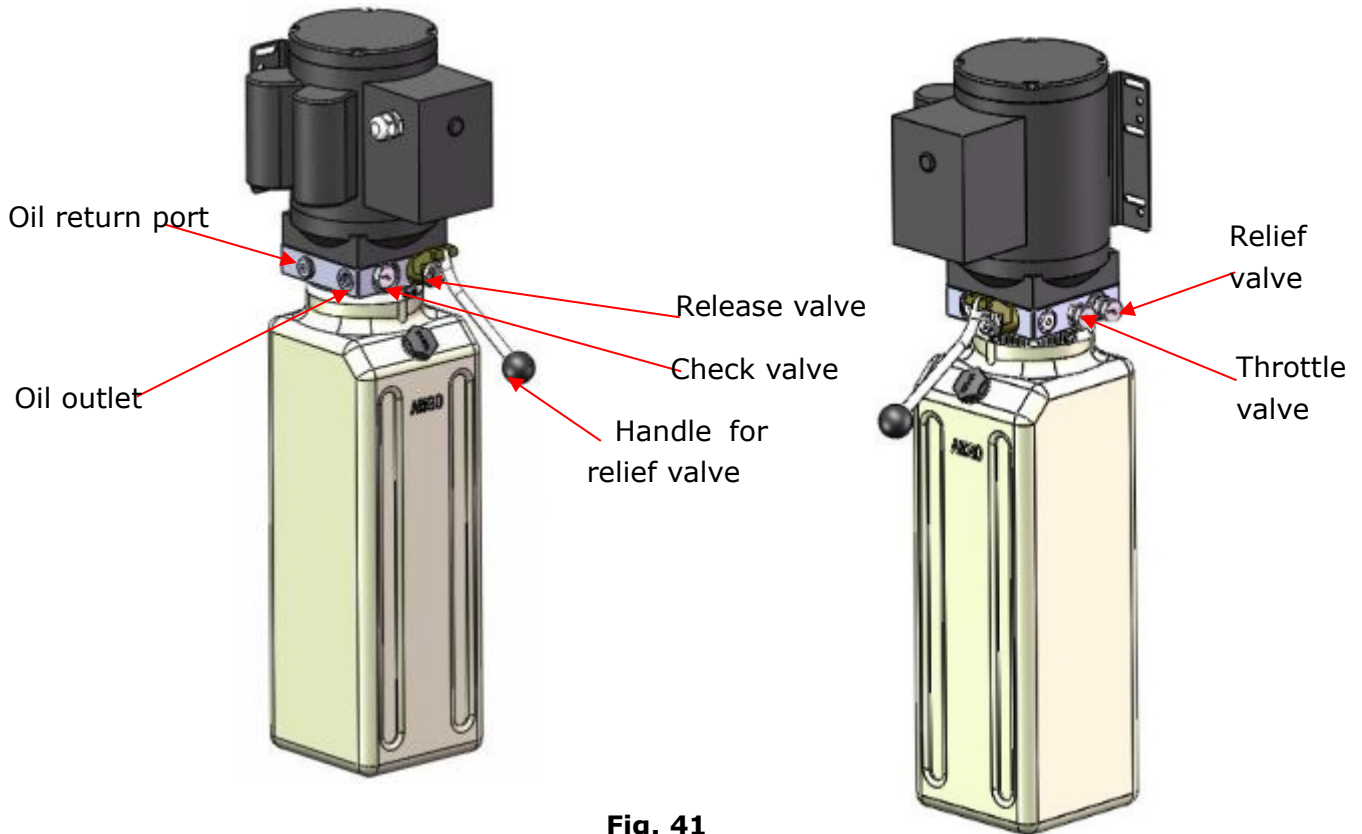

Fig. 41

V. TEST RUN

1. Fill the reservoir with Hydraulic Oil (**Note:** In consideration of Power Unit's durability, please use **Hydraulic Oil 46#**).
2. Press the control button on the power unit till the cables are strained. Check the cables and confirm they are in the proper pulley position. Make sure the cables are not across.
3. Press the release valve handle on the power unit to lock the cross-beam on the safety ladders, and then adjust the platforms to be level by adjusting the nuts of safety ladders. Tighten the nuts above and under the safety ladder top plate after leveling.
4. Adjust the cable fitting hex nuts to make platforms and four safety locks work synchronously. You need to run the lift up and down for several times, meanwhile do the synchronous adjustment till the four safety devices can lock and release at the same time.
5. Adjust the clearance between the column and the plastic slider of cross-beam, make sure the plastic slider can be slid in the column smoothly. Do not tighten too much of the sliding block.

- After finishing the above adjustment, test running the lift with load. Run the lift with platforms in low position first, make sure the platforms can rise and lower synchronously and the safety device can lock and release synchronously. And then test run the lift to the top completely. If there are anything improper, repeat the above adjustment.

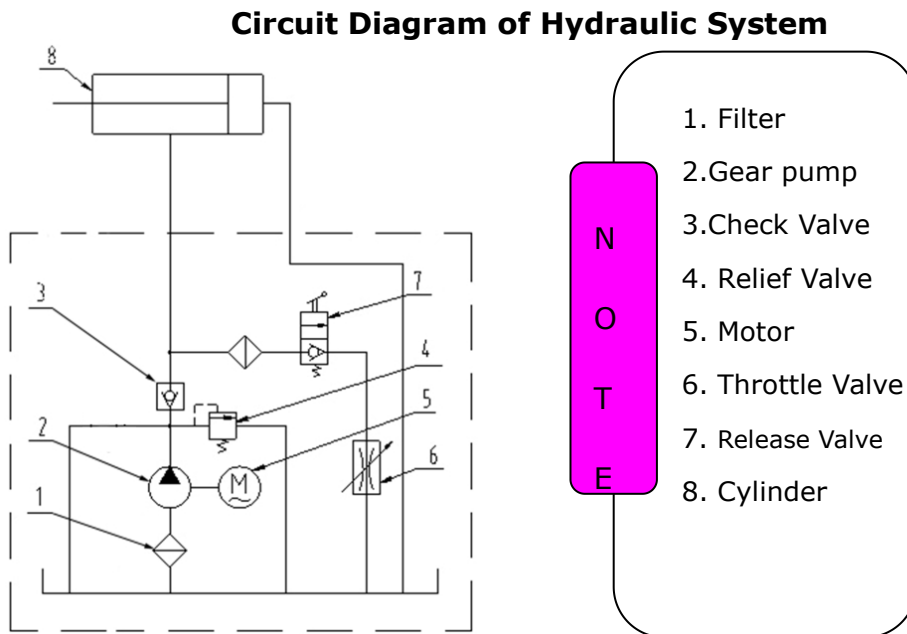

Fig. 42

VI. OPERATION INSTRUCTIONS

To lift vehicle

- Keep clean of environment near the lift.
- Drive vehicle to the platform and put on the brake.
- Take off the drive-in ramp, install rear wheel stop plates to the drive-in ramp position.
- Turn on the power and press the control button, raise the lift to the working position.

Note: make sure the vehicle is steady when the lift is raised.

- Press the release valve handle to lock the lift in the safety position. Make sure the safety device is locked at the same height.

To lower vehicle

- Be sure the clearance of around and under the lift, only leaving operator in lift area.
- Press the control button, the lift will be raised for 3-5 seconds, and then press the

safety release handle, make sure the safety device released, press the release valve handle by the other hand, then the lift starts being lowered automatically.

3. Drive away the vehicle when the lift is lowered to the lowest position. Take off the rear wheel stop plates and install drive-in ramp, then left the lift.
4. Turn off the power.

VII. MAINTENANCE SCHEDULE

Monthly:

1. Lubricate cable with lubricant;
2. Check all cable connection, bolts and pins to insure proper mounting;
3. Make a visual inspection of all hydraulic hoses/lines for possible wear or leakage;
4. Lubricate all rollers, safety devices with 90wt. gear oil or equivalent.

Every six months:

1. Make a visual inspection of all moving parts for possible wear, interference or damage.
2. Check and adjust as necessary, equalizer tension to insure level lifting.
3. Check columns for plumbness.

VIII. TROUBLE SHOOTING

TROUBLE	CAUSE	REMEDY
Motor does not run	<ol style="list-style-type: none"> 1. Button does not work 2. Wiring connections are not in good condition 3. Motor burned out 4. AC contactor burned out 	<ol style="list-style-type: none"> 1. Replace button 2. Repair all wiring connections 3. Repair or replace motor 4. Replace AC contactor
Motor runs but the lift is not raised	<ol style="list-style-type: none"> 1. Motor runs in reverse rotation 2. Release valve in damage 3. Gear pump in damage 4. Relief valve or check valve in damage 5. Low oil level 	<ol style="list-style-type: none"> 1. Reverse two power wire 2. Repair or replace 3. Repair or replace 4. Repair or replace 5. Fill tank
Lift does not stay up	<ol style="list-style-type: none"> 1. Release valve out of work 2. Relief valve or check valve leakage. 3. Cylinder or fittings leaks 	Repair or replace
Lift raises too slow	<ol style="list-style-type: none"> 1. Oil line is jammed 2. Motor running on low voltage 3. Oil mixed with Air 4. Pump leaks 5. Overload lifting 	<ol style="list-style-type: none"> 1. Clean the oil line 2. Check electrical system 3. Fill tank 4. Repair or replace pump 5. Check load
Lift cannot lower	<ol style="list-style-type: none"> 1. Safety device are not in activated 2. Release valve damaged 	<ol style="list-style-type: none"> 1. Operate again 2. Repair or replace

IX. SCARPING OF EQUIPMENT

Once the equipment is unusable and needs to be scarped, please follow the local laws and regulations.

AMGO HYDRAULIC CORPORA

1931 Joe Rogers Blvd, Manning, South Carolina, Zip:29102

Tel: (803) 505-6410

fax: (803) 505-6410

Manual No.: 72247201

Revision Date: 2019/12