

# SL-Series Air Lift Owner's Manual

Safety Instructions, Operating Instructions, Specifications, Parts List & Warranty

Model: SL-3086, SL-5486, SL-3090, SL-6090



**WARNING: READ INSTRUCTIONS BEFORE OPERATING**



### *Safety Quick Points:*

1. Center load – 1,200 lb. rated capacity
2. Recommended air pressure is 110 psi
3. Keep Safety Bar Engaged with Variable Lock Heights When In Use
4. To lower, raise table off safety bar, flip bar up and secure to tension clips, release air slowly lowering table to desired height
5. Keep hands and tools from under table – avoid multiple pinch points
6. Do not load table or climb onto table when elevated
7. Use caution when placing vehicle onto lift – riding vehicle onto lift is not recommended
8. Ground surface should be flat and level
9. Tie down straps are recommended with eye bolts secured to table
10. Ensure air hose is clear from frame when lowering to avoid pinching hose



NOTE: READ ENTIRE MANUAL TO COMPLY WITH ALL SAFETY AND SERVICE PRECAUTIONS. DEATH, PERSONAL INJURY AND/OR PROPERTY DAMAGE MAY OCCUR UNLESS INSTRUCTIONS ARE FOLLOWED CAREFULLY.

**Shipping Contents:** The SL-Series Lifts ship with several loose parts, including a ramp and attachments. Check the contents for completeness.

### **Assembly:**

1. Remove the packaging.
2. Check the contents.
3. Assemble the eyebolts to the lift top.
4. Assemble an airline connector to the air valve into the port marked with an "A".
5. Assemble the ramp to the end of the lift.
6. Assemble as needed the accessories such as cycle vise or wheel chock to the lift table.
7. When using side extensions; place the support bar through the 2" square tubing at the bottom of lift.
8. Attach Side Extensions to the lift if applicable.
9. Operate the lift without any load for the first time to check operation and speed.

### **Lift Operation:**

1. Always check for vertical clearance prior to operating the lift.
2. Use the ramp(s) to place vehicle on the lift. **Loads must be centered on the table at all times.**
3. Always restrain the vehicle being lifted, strap to the eyebolts.
4. Use the foot valve to raise the lift, release safety bar from tension clips, and lower to engage the safety bar at desired working heights.
5. Ensure that the air hose is clear from the frame when lowered into the lowest position.

### **Product Specifications:**

Model	Capacity	Weight	Dimensions
SL-3086	1200 lbs	445 lbs.	30" x 86"
SL-5486	1200 lbs		30" x 86"
SL-3090	1200 lbs	460 lbs	30" x 90"
SL-6090	1200 lbs	615 lbs	60" x 90" – 4 Side Extensions
SL-6090T	1200 lbs	540 lbs	60"x90" – 2 Side Extensions

**Parts Drawing - Parts List:**

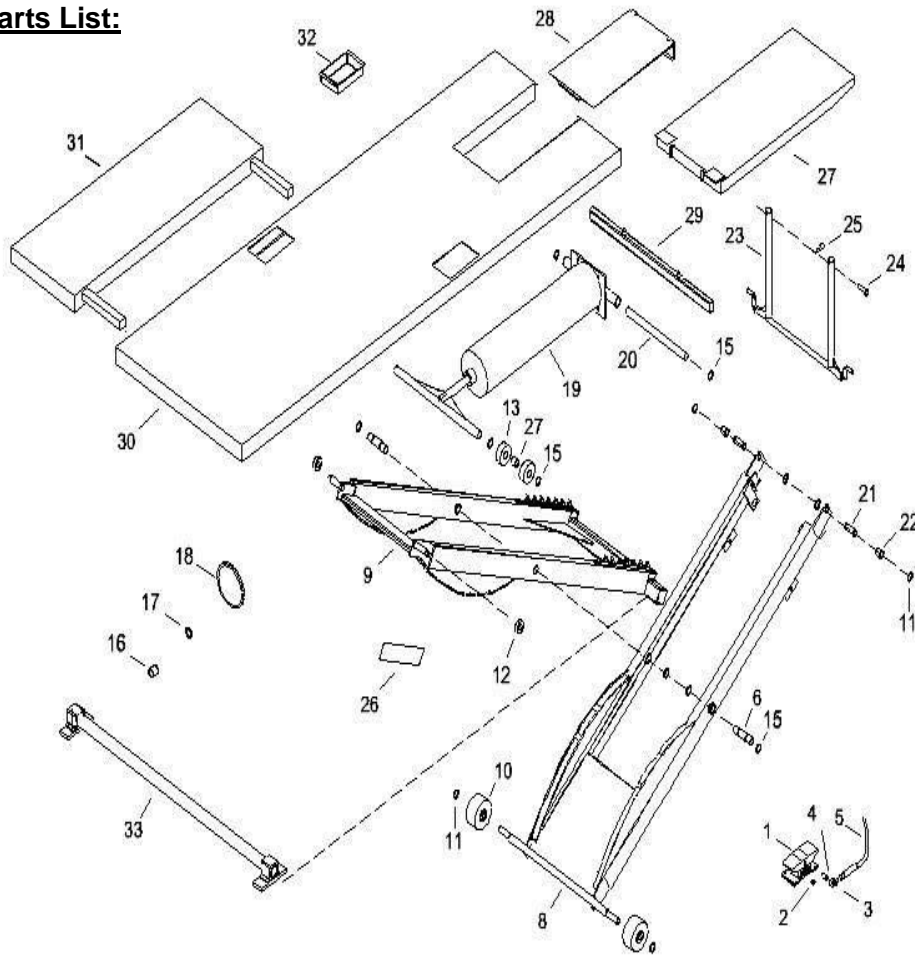

Item	Part No.	Description	Qty	Item	Part No.	Description	Qty
1	4F230C	Air Valve, Foot Pedal	1	19	2085	Cylinder, Air	1
2	14CSPLG-GALV	Hex Socket Plug, 1/4 NPT	1	20	2053	Pin, Cylinder Pivot	1
3	2176	Elbow, Street 1/4 NPT	2	21	2054	Pin, Top	2
4	2176	Hex Nipple, Brass 1/4 NPT	1	22	2506-2	Spacer, Top	2
5	HFZ3806YW2B	Hose, Swivel, Whip, 6' x 3/8"	1	*23	2066-1	Detent Bar Assy	1
6	2005	Shaft, Pivot	2	*23	2066-2	Detent Bar Assy	1
7	K-14A	Zerk, Grease	2	24	2055	Pin Detent Bar	2
8	2106	Frame, Inside Welded	1	25	11 HP	Hairpin Clip	2
9	2107	Frame, Outside Welded	1	*26	2088	Decal, SL-2482	1
10	2100	Wheel, 4" Phenolic	2	*26	2089	Decal, SL-3090	1
11	SH-75	Snap Ring, 3/4" external	6	*27	2009B	Ramp	1-4
12	1628-2RS	Bearing, ball sealed	2	*28	2037B	Dropout	1
13	5305-2RS	Bearing, ball sealed	4	*29	2073	Table Support	1
14	2508-1	Spacer	2	*30	2000B	Top, SL3086	1
15	SH-75	Snap Ring, 3/4" external	10	*30	2015B	Top, SL2482	1
^16	2011	Busing, Nylon	1	*30	2035	Top, SL3090	1
^17	2080	Seal, U-Cup, Rod	1	*31	2032B	Side Extension	1-4
^18	2081	Seal, U-Cup, Piston	1	*32	2038	Parts Tray	2
				*33	2058	Stabilizer	1

## **OPERATIONAL CHECKS AND MAINTENANCE:**

1. Check all working parts for any damage or disconnection
2. Check air hose connections for leaks
3. Add air tool oil every 3-6 months as needed through foot valve supply line
4. Grease pivot pins as needed
5. Grease bearing cams and table bearing tracks as needed

*(Grease requirements vary based on use and loads applied)*

### **SL Series Lift Limited Warranty:**

HMC Industries, Inc warrants to the original purchaser of this product.

- Limited 10 Year Warranty on the Frame and Table Structure. Not included is wear to center stand use, wearable parts such as pins, bearings, seals and wheels.
- 3 Year Limited Warranty on wearable parts such as pins, bearings, seals, wheels, foot valve, wheel chocks, cycle vises, extensions and cylinders.

Notice of defective part must be received in writing at HMC Industries within warranty term from purchase date. All defective parts must be returned to HMC Industries, and which, upon our examination any parts which are defective in manufacture or workmanship, will be replaced or put in good operating condition. This warranty does not apply to damage resulting in accident, improper installation, repair, operation or maintenance negligence or neglect. The cost of such replacement or repair shall be exclusive remedy for any breach of warranty. HMC Industries makes no warranty or merchantability, makes no warranty of fitness for a particular purpose and makes no other warranty expressed or implied, including implied warranty arising from the course or dealing or usage of the trade.

