



**Blackhawk
Automotive**™

Blackhawk Automotive is a Licensed Trade Mark

Made by SFA Companies, Kansas City, MO

Air Hydraulic Bottle Jack

Operating Instructions & Parts Manual

Model
BH2500

Capacity
50 Ton



This is the safety alert symbol. It is used to alert you to potential personal injury hazards. Obey all safety messages that follow this symbol to avoid possible injury or death.



ADVERTENCIA

- Leer, comprender, y seguir las instrucciones antes de utilizar el aparato.
- El manual de instrucciones y la información de seguridad deben estar comunicado en lengua del operador antes del uso.
- No seguir estas indicaciones puede causar daños personales o materiales.



WARNING

To avoid **crushing and related injuries**:



NEVER work on, under or around a load supported only by a hydraulic jack. **ALWAYS** use adequately rated jack stands.

SFA Companies
10939 N. Pomona Ave. Kansas City, MO 64153
sales@blackhawk-automotive.com

Read this manual and follow all the Safety Rules and Operating Instructions before using this product.

Made in Taiwan
BH2500-M0 rev 11/07

SAFETY and GENERAL INFORMATION

Save these instructions. For your safety *read, understand, and follow* the information provided with and on this jack. The owner and operator of this equipment shall have an understanding of this jack and safe operating procedures before attempting to use. The owner and operator shall be aware that use and repair of this product may require special skills and knowledge. Instructions and safety information shall be conveyed in the operator's native language before use of this jack is authorized. If any doubt exists as to the safe and proper use of this jack, remove from service immediately.

Inspect before each use. Do not use if broken, bent, cracked, or damaged parts (including labels) are noted. Any jack that appears damaged in any way, operates abnormally or is missing parts, shall be removed from service immediately and the manufacturer notified. If you suspect that the jack was subjected to a shock load (a load dropped suddenly, unexpectedly upon it), immediately discontinue use until the jack has been checked by a factory authorized service center (contact distributor or manufacturer for list of Authorized Service Centers). It is recommended that an annual inspection be done by qualified personnel. Replace worn or damaged parts with Blackhawk authorized replacement parts only. Labels and owner's manuals are available from manufacturer.

PRODUCT DESCRIPTION

Blackhawk Automotive Air Actuated Hydraulic Bottle Jack is designed to lift, not support, rated capacity loads consisting of one end of a vehicle. Immediately after lifting, the load must be supported by a pair of appropriately rated jack stands. Ensure that air source can dedicate 7.8 CFM @ 110-175 psi to each jack operated. A minimum of 150 psi air pressure is required to raise rated capacity load.



Never use hydraulic jack as a stand alone device. After lifting, immediately support the lifted load with a pair of appropriately rated jack stands.

PREPARATION

Before Use

1. Verify that the product and the application are compatible, if in doubt contact Customer Support (816)891-6390.
2. Before using this product, read the operator's manual completely and familiarize yourself thoroughly with the product, its components and recognize the hazards associated with its use.
3. Assemble handle, ensure spring clips align with slots.
4. To familiarize yourself with basic operation, use the notched end of provided handle to engage and turn the release valve:
 - a. Clockwise until firm resistance is felt to further turning. This is the '**CLOSED**' release valve position used to **raise** the ram plunger.
 - b. Counter-clockwise, but no more than 1/2 turn from the closed position. This is the '**OPEN**' release valve position used to **lower** the ram plunger.
5. With ram fully retracted, locate and remove the oil filler screw. Connect air hose to lift control valve, then squeeze lift control valve to operate pump for few seconds. This will help release any pressurized air, which may be trapped within the reservoir. Ensure the oil level is just below the oil filler hole. Reinstall the oil filler screw.
6. Pour a teaspoon of good quality, air tool lubricant into the air supply inlet of the lift control valve. Connect to air supply and operate for 3 seconds to evenly distribute lubricant.
7. This product is equipped with the popular 1/4" NPT air coupler. When installing a different air coupler of your choice, ensure that thread tape or compound is used when servicing connections. To ensure dependable, trouble free operation an inline air dryer and oiler is recommended.
8. Check that the pump operates smoothly before putting into service. Replace worn or damaged parts and assemblies with Blackhawk Automotive authorized replacement parts only.

Bleeding / Venting Trapped Air

With the release valve in the OPEN position (4b above) and with ram plunger fully lowered, locate and remove the oil filler screw. Squeeze lift control valve to operate pump for few seconds. This will help release any pressurized air which may be trapped within the reservoir. Oil level should be even with the bottom of the oil filler hole. Reinstall the oil filler screw.

SPECIFICATIONS

Model	Capacity	Base Size (L x W)	Saddle Diameter	Min. Height	Max. Height	Hydraulic Lift	Volume Hyd. Oil	Net Weight
BH2500	50 Ton	10 7/8" x 7 3/8"	2 1/2"	12"	19"	7"	1650 mL	129 lb.

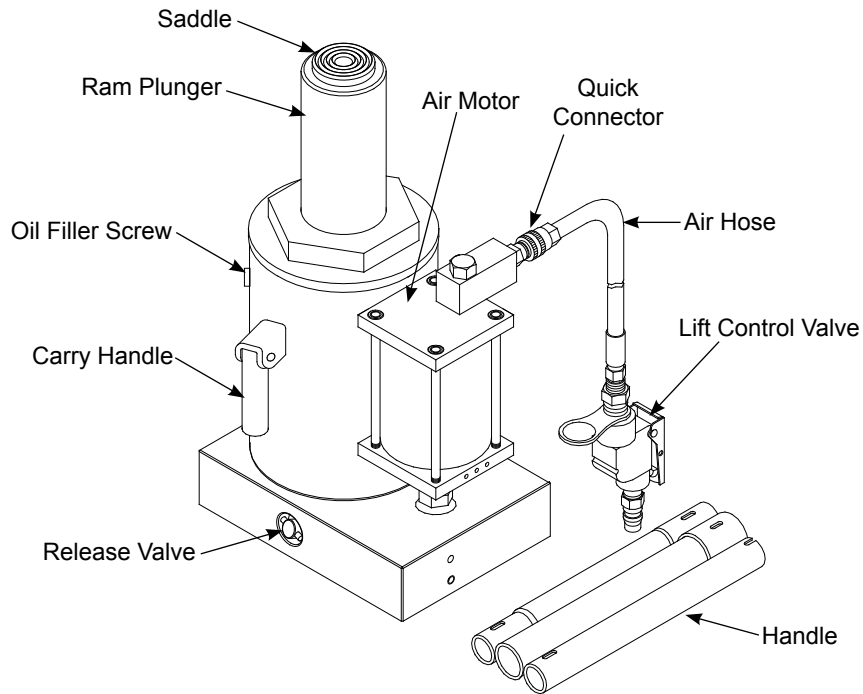
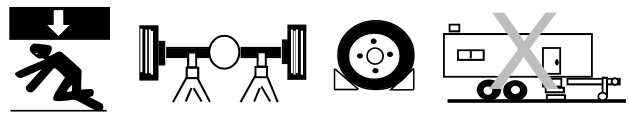

Figure 1 - BH2500 Nomenclature

WARNING

- **Study, understand, and follow** all printed materials provided with/on this product before use.
- **Do not** exceed rated capacity.
- **This is a lifting device only!**
- **Immediately** after lifting, support the load with **a pair** of appropriately rated jack stands.
- Use only on hard, level surface.
- Do not use adapters or accessories that are not provided initially.
- Lift only on areas of the vehicle as specified by the vehicle manufacturer.
- Never wire, clamp or otherwise disable the lift control valve to function by other than operator's hand.
- No alterations shall be made to this product.
- Failure to heed these markings may result in personal injury and/or property damage.

WARNING



To avoid **crushing and related injuries**:

- **Never** work on, under or around a load supported only by hydraulic jack.
- **Always** use adequately rated jack stands.
- Chock each unlifted tire in both directions.
- **Do not** use this device to lift, level, lower, support nor move a house, mobile home, travel trailer, camper or any building structure.
- **Be alert** and **sober** when using this product. Do not operate under the influence of drugs or alcohol.

 *Only attachments and/or adapters supplied by the manufacturer shall be used. Lift only on areas of the vehicle as specified by the vehicle manufacturer.*

OPERATION

Raising the Ram Plunger

1. Assemble handle, ensure that spring clips align with slots.
2. Place vehicle in the park, with emergency brake on and wheel securely chocked to prevent inadvertent vehicle movement.
3. Locate and close release valve by turning handle clockwise until firm resistance is felt to further thread engagement.
4. Verify lift point, center jack saddle under lift point.
5. Squeeze the lift control valve in order to raise saddle to contact lift point. To lift, continue pumping until load reaches desired height.
6. **Immediately** secure lifted load with appropriately rated jack stands.

 *Use only the handle provided by jack manufacturer. The handle provided with this jack will safely engage the release valve. If handle is worn, operates abnormally, or will not positively engage the release valve, **STOP**, discontinue use of the jack until a factory replacement handle can be acquired.*

 *Do not use an extender on the air hose or the operating handle.*

Lowering

 *Make certain that all personnel are clear of the load before lowering. **Control** the rate of descent of the load **at all times**. The **more** you open the release valve, the **faster** the load descends.*

1. Raise load high enough to clear the jack stands, then carefully remove jack stands (**always** used in pairs).
2. Slowly turn the handle counter-clockwise, but no more than 1/2 turn. If the load fails to lower:
 - a. Use another jack to raise the vehicle high enough to reinstall jack stands.
 - b. Remove the affected jack and then the stands.
 - c. Lower the load by turning the release valve counter-clockwise, but no more than 1/2 turn.
3. After removing jack from under the load, push ram and handle sleeve down to reduce exposure to rust and contamination.

MAINTENANCE

Important: Use only good grade hydraulic jack oil. Avoid mixing different types of fluid and **Never** use brake fluid, turbine oil, transmission fluid, motor oil or glycerin. Improper fluid can cause failure of the jack and the potential for sudden and immediate loss of load. We recommend Hein-Werner HW93291 or equivalent.

Adding oil

1. With ram plunger fully lowered and air supply disconnected, set jack in its upright, level position. Remove oil filler screw.
2. Fill with oil until just below the rim of the oil filler hole. Reinstall the oil filler screw.

Changing oil

For best performance and longest life, replace the complete fluid supply at least once per year.

1. With ram plunger fully lowered and air supply disconnected, remove the oil filler screw.
2. Lay the jack on its side and drain the fluid into a suitable container.

Note: Dispose of hydraulic oil in accordance with local regulations.

3. Fill with oil until just below the rim of the oil filler hole. Reinstall the oil filler screw.

Lubrication

Air pump should be internally lubricated before each use. Use good quality air tool lubricant. If no inline oiler is used, pour a teaspoon of air tool oil into the air control valve inlet. Operate the jack with air pressure to fully distribute the oil inside the air motor.

Cleaning

Periodically check the ram for signs of rust/corrosion. Clean as needed and wipe with oily cloth.

Note: Never use sandpaper or abrasive material on ram surface!

Storage

When not in use, store the jack with ram plunger fully retracted and air supply disconnected.

TROUBLESHOOTING

Symptom	Possible Causes	Corrective Action
Jack will not lift load	<ul style="list-style-type: none"> • Release valve not tightly closed • Overload condition • Air pressure inadequate 	<ul style="list-style-type: none"> • Ensure release valve tightly closed • Remedy overload condition • Ensure adequate air pressure
Jack will lift, but not maintain pressure	<ul style="list-style-type: none"> • Release valve not tightly closed • Hydraulic unit malfunction 	<ul style="list-style-type: none"> • Ensure release valve tightly closed • Discontinue use, contact Blackhawk Technical Service
Jack will not lower after unloading	<ul style="list-style-type: none"> • Reservoir overfilled 	<ul style="list-style-type: none"> • Drain fluid to proper level
Poor lift performance	<ul style="list-style-type: none"> • Fluid level low • Air trapped in system 	<ul style="list-style-type: none"> • Ensure proper fluid level • With ram fully retracted, remove oil filler screw to let pressurized air escape. Reinstall oil filler screw
Will not lift to full extension	<ul style="list-style-type: none"> • Fluid level low 	<ul style="list-style-type: none"> • Ensure proper fluid level

REPLACEMENT PARTS

(refer to page 6 & 7)

Not all components of the jack are replacement items, but are illustrated as a convenient reference of location and position in the assembly sequence. When ordering parts, give Model number, serial number and parts description. Call or write for current pricing: SFA Companies, 10939 N. Pomona Ave. Kansas City, MO 64153, U.S.A. Tel:(816)891-6390 Fax:(816)891-6599 E-Mail: sales@blackhawk-automotive.com

Replacement Parts Illustration for Model BH2500

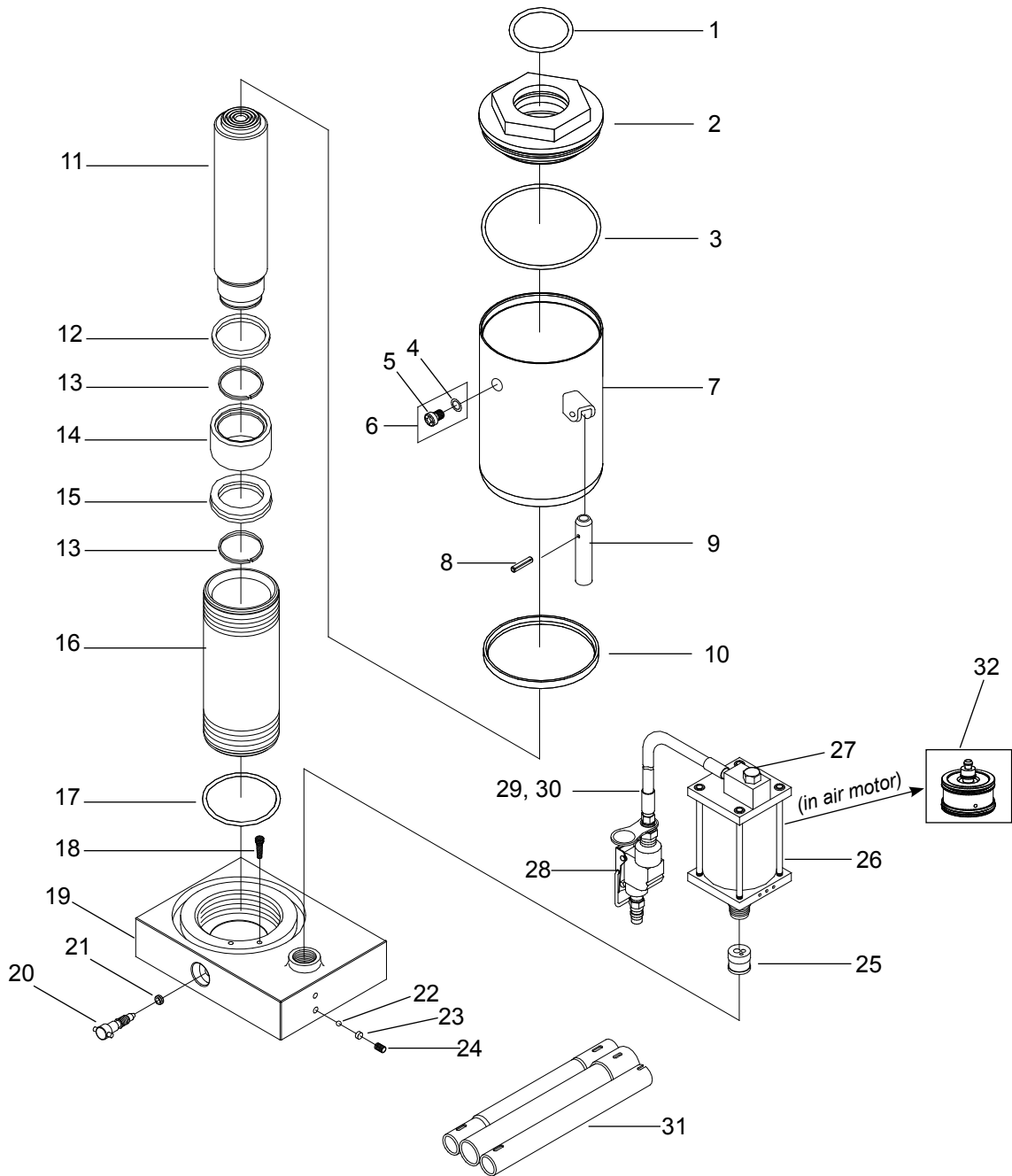

Figure 2 - Model BH2500 Replacement Parts Illustration

Replacement Parts List for Model BH2500

Item	Part#	Description	Qty
1	*	O-ring	1
2	N/A	Top Nut	1
3	*	O-ring	1
4	N/A	O-ring	1
5	N/A	Filler screw	1
6	*(324-4-1900-208)	Filler Screw Assembly	1
7	N/A	Reservoir	1
8	601-4-0080-009	Spring Pin	2
9	244-6-1806-205	Carry Handle	2
10	*	Oil Seal	1
11	N/A	Ram Plunger	1
12	244-6-1205-108	Collar	1
13	244-6-1204-207	Snap Ring	2
14	N/A	Ram Bearing	1
15	*	U-cup	1
16	N/A	Cylinder	1
17	*	O-ring	1
18	532-8-0050-024	Filter	1
19	N/A	Base	1
20	238-6-1701-403	Release Valve	1
21	*	Oil Seal	1
22	601-7-0008-009	Steel Ball	1
23	503-9-0067-103	Stud	1
24	644-1-0080-031	Screw	1
25	A20-4-1500-106	Hyd. Cartridge	1
26	A27010-0001	Air Motor	1
27	A27010-0002	Air Inlet Swivel	1
28	A20060-0007	Lift Control Valve	1
29	A20060-0006	Air Hose only	1
30	A20060-0005	Air Hose Assembly	1
31	181-3-2100-103	Handle Assembly	1
32	A270-01100-000	Piston, Air Motor	1
(*)	A50-3-9905-100	Repair Kit	1

(*) - parts included in Repair Kit
 N/A - parts not available, replace entire unit

ONE YEAR LIMITED WARRANTY

For a period of one (1) year from date of purchase, SFA Companies will repair or replace, at its option, without charge, any of its products which fails due to a defect in material or workmanship under normal usage. This limited warranty is a consumer's exclusive remedy.

Performance of any obligation under this warranty may be obtained by returning the warranted product, freight prepaid, to SFA Companies Warranty Service Department, 10939 N. Pomona Ave., Kansas City, MO 64153.

Except where such limitations and exclusions are specifically prohibited by applicable law,

(1) THE CONSUMER'S SOLE AND EXCLUSIVE REMEDY SHALL BE THE REPAIR OR REPLACEMENT OF DEFECTIVE PRODUCTS AS DESCRIBED ABOVE.

(2) SFA Companies SHALL NOT BE LIABLE FOR ANY CONSEQUENTIAL OR INCIDENTAL DAMAGE OR LOSS WHATSOEVER.

(3) ANY IMPLIED WARRANTIES, INCLUDING WITHOUT LIMITATION THE IMPLIED WARRANTIES OF MERCHANTABILITY AND FITNESS FOR A PARTICULAR PURPOSE, SHALL BE LIMITED TO ONE YEAR, OTHERWISE THE REPAIR, REPLACEMENT OR REFUND AS PROVIDED UNDER THIS EXPRESS LIMITED WARRANTY IS THE EXCLUSIVE REMEDY OF THE CONSUMER, AND IS PROVIDED IN LIEU OF ALL OTHER WARRANTIES, EXPRESS OR IMPLIED.

(4) ANY MODIFICATION, ALTERATION, ABUSE, UNAUTHORIZED SERVICE OR ORNAMENTAL DESIGN VOIDS THIS WARRANTY AND IS NOT COVERED BY THIS WARRANTY.

Some states do not allow limitations on how long an implied warranty lasts, so the above limitation may not apply to you. Some states do not allow the exclusion or limitation of incidental or consequential damages, so the above limitation or exclusion may not apply to you. This warranty gives you specific legal rights, and you may also have other rights, which vary from state to state.



SFA Companies
10939 N. Pomona Ave. Kansas City, MO 64153
816-891-6390
sales@blackhawk-automotive.com